

# Pearl

DRUMS



# Pearl

DRUMS  
ARTISTS



PHOTOS READ FROM LEFT TO RIGHT

TOP ROW—Harold Chang • Lynn Coulter • Richard Brown • Sonny Babbidge  
2ND ROW—Joey Herrick • John Wolters • Roy McCurdy • Eddie Burrell  
3RD ROW—James Gadson • Deane Hagen • Darryl Brown • David Drubin • Colin Bailey • Chris Augustine  
4TH ROW—Hal Gordon • Elliot Franks • Dennis Dragon • Ken Collier • Albie Berk • Gene Estes  
5TH ROW—Terry Jenkins • Fred Krc • Wesley "Gator" Watson • Micky McMeel • Allan Estes • John Drase  
6TH ROW—Bill Hawkins • Tony Coleman • Bill Meeker • Mel Lee • Don LeJeanne • Robbie Gonsalves  
7TH ROW—Al Thompson • Gene Pello • Frank Logar • Byron Metcalf • Jerry White • Ian Douglas Wright  
BOTTOM ROW—Ron Jarrell • Jesse Sailes • Mark Morris • Carl Mattola • Stan Glogocheski • Terry Silverlight



PHOTOS READ FROM LEFT TO RIGHT

- TOP ROW—Bob Zimmitti • Bobby Daniels • Don Bailey • Denny Dixon • Peter Wolland • John Gilston  
 2ND ROW—Candy Finch • Jerry Williams • Cecil Grubbs • Della Rey • Cliff Whitelegg • Tom Gillen  
 3RD ROW—Dom Fam • Dave Tucker • Jerry Cordasco • Dick Allen • Jerry Carrigan • Gary Wallace  
 4TH ROW—Doug Sides • Norman Jeffries • Bill Martinez • Neal Sausen • John Tirabasso • Dennis Alexander  
 5TH ROW—Ronald Hart • Doug Dean • Tommy Rundell • Gary Faile • Rudy Regaldo • Larry Dent  
 6TH ROW—John Hernandez • Fred Pierce • Mitchell Peters • Theresa Justus • Billy James • John Perett  
 7TH ROW—Peter Magadini • Omar Martinez • Jim Knudson • Charlie Allen Martin • Howard Kurhan • Warren Odze  
 BOTTOM ROW—Charlie Hammond • Clyde Brooks • Elliott Burns • Dave Bedell • Tommy Cozart • Peter Limonick



Shown in Pure White. Cymbals not included.

**MODEL F-11D FIBERGLASS SHELLS  
FW-11D FIBERGLASS LINED 9-PLY  
WOOD SHELLS\***



Larrie Londin • Chester Thompson  
Les DeMerle • Harvey Lang • Biff Adam

**OUTFIT INCLUDES**

**Model:**

- 224** 14x24 Bass Drum (Players Right), 786 Spurs, 717-3 V.S.\*\* Double Tom Holder base plate, 814 V.S. Cymbal boom arm, 732 internal felt muffler strip.
- 222** 14x22 Bass Drum, 786 Spurs, 717-3 V.S. Double Tom holder base plate, 720-S Hi-Hat to Bass Drum attachment, 782 internal felt muffler strip.
- FG06** 5 1/2x6 Concert Tom, 913-1 clip bracket, 913-1A double clip (attaches to FG08).
- FG08** 5 1/2x8 Concert Tom, 913-1 clip bracket, 913-1A double clip (attaches to FG10).
- FG10** 6 1/2x10 Concert Tom, 913-1 clip bracket, 717-1 V.S. Tom bracket, 717-2L V.S. Tom arm.
- 213** Two 9x13 Tom Toms, Two 717-1 V.S. Tom brackets, Two 717-2 V.S. Tom arms, 734 muffler.
- 2114** 14x14 Tom Tom, 781 legs, 734 muffler.
- 216** 16x16 Tom Tom, 781 legs, 734 muffler.
- 2118** 16x18 Tom Tom, 781 legs, 734 muffler.
- 4814** 5x14 Jupiter Snare Drum, 734 muffler.
- 800** Hi-Hat
- 806** Snare Drum Stand
- 803N** Two Cymbal Stands
- 810** Two Bass Drum Pedals

See price list for possible substitutions of components, heads, and available finishes.  
\*All Concert Toms have fiberglass shells. \*\*Two-Set System.





*Shown in Topwood Cymbals not included*

**MODEL** F-8 FIBERGLASS SHELLS  
FW-8 FIBERGLASS LINED 9-PLY  
WOOD SHELLS\*



Art Blakey • Don Lamond  
Bill Lavorgna • Stix Hooper • John Guerin

**OUTFIT INCLUDES**

- Model:**  
**222** 14x22 Bass Drum, 786 Spurs, 717-3 V.S.\*\* Double Tom Holder base plate, 732 internal felt muffler strip.
- FG06** 5 1/2x6 Concert Tom, 913-1 clip bracket, 913-1A double clip attached (attaches to FG08)
- FG08** 5 1/2x8 Concert Tom, 913-1 clip bracket, 717-1 V.S. Tom bracket
- FG10** 6 1/2x10 Concert Tom, 717-1 V.S. Tom bracket
- FG12** 8x12 Concert Tom, 717-1 V.S. Tom bracket, 717-2 V.S. Tom arm
- FG13** 9x13 Concert Tom, 717-1 V.S. Tom bracket, 717-2 V.S. Tom arm
- 2114** 14x14 Tom-Tom, 781 legs, 734 muffler
- 4814** 5x14 Jupiter Snare Drum, 734 muffler
- 800** Hi-Hat
- 803N** Two Cymbal Stands
- 806** Snare Drum Stand
- 810** Bass Drum Pedal
- 989** V.S. Double Tom Floor Stand

See price list for possible substitutions, components, features and available finishes.  
\*All Concert Tom & Floor Stand Shells \*\*V.S. Set System



Shown in Chrome. Cymbals not included

**MODEL F-6VP FIBERGLASS SHELLS\***  
**FW-6VP FIBERGLASS LINED 9-PLY**  
**WOOD SHELLS\***



Buddy Harman • Peter Criss  
Kenny Malone • Randy May • Alphonse Mouzon

**OUTFIT INCLUDES:**

- Model:** 14x22 Bass Drum, 786 Spurs, 717-3 V.S.\*\* Double  
**222** Tom Holder base plate, 732 internal felt muffler strip
- VPC10** 10 $\frac{1}{2}$ x10 Vari-Pitch Cannon, 717-1 V.S., Tom  
bracket, 717-2 V.S., Tom arm.
- VPC12** 10 $\frac{1}{2}$ x12 Vari-Pitch Cannon, 717-1 V.S., Tom  
bracket, 717-2 V.S., Tom arm, 813 V.S. adaptor.
- VPC14** 10 $\frac{1}{2}$ x14 Vari-Pitch Cannon, 717-1 V.S., Tom  
bracket, 717-2 V.S., Tom arm.
- VPC16** 10 $\frac{1}{2}$ x16 Vari-Pitch Cannon, 781 legs.
- VPS514** 5x14 Vari-Pitch Snare Drum, chrome plated, 834  
Vari-Pitch snare muffler.
- 800** Hi-Hat
- 803N** Two Cymbal Stands
- 806** Snare Drum Stand
- 810** Bass Drum Pedal

See price list for possible substitutions of components, heads and available finishes.  
\*Vari-Pitch Drums have chromed shells. \*\*Vari-Pitch System.



Shown in Red Glass. Cymbals Not Included

**MODEL** F-5 FIBERGLASS SHELLS  
FW-5 FIBERGLASS LINED 9-PLY  
WOOD SHELLS

**OUTFIT INCLUDES**

- Model:**  
**222** 14x22 Bass Drum, 786 Spurs, 717-3 V.S.\*\* Double Tom Holder base plate, 732 internal felt muffler strip.  
**212** 8x12 Tom Tom, 717-1 V.S. Tom bracket, 717-2 V.S. Tom arm, 734 muffler.  
**213** 9x13 Tom Tom, 717-1 V.S. Tom bracket, 717-2 V.S. Tom arm, 734 muffler.  
**216** 16x16 Tom Tom, 781 legs, 734 muffler.  
**B4514** 5x14 Snare Drum, 734 muffler.  
**800** Hi-Hat  
**803N** Two Cymbal Stands  
**806** Snare Drum Stand  
**810** Bass Drum Pedal



Butch Miles • Cozy Cole  
Paul Humphrey • Mark Stevens • Keith Knudson

See price lists for possible substitutions of components, trade and available finishes.  
\*\*Van-Sel System



# Pearl

DRUMS

W-SERIES DELUXE OUTFITS

9



Shown in White. Cymbals not included.

## MODEL W-5 DELUXE 9-PLY WOOD SHELLS

## OUTFIT INCLUDES:

- Model:**  
**W222** 14x22 Bass Drum, 786 Spurs, 727-3 V.S.\*\* Double Tom Holder base plate, 813 adapter, 732 internal felt muffler strip.  
**W212** 8x12 Tom Tom, 717-1 V.S. Tom bracket, 727-2 V.S. Tom arm, 734 muffler.  
**W213** 9x13 Tom Tom, 717-1 V.S. Tom bracket, 727-2 V.S. Tom arm, 734 muffler.  
**W216** 16x16 Tom Tom, 781 legs, 734 muffler.  
**D4514** 5x14 Snare Drum, 734 muffler.  
**805** Hi-Hat **706** Snare Drum Stand  
**703** Two Cymbal Stands **710** Bass Drum Pedal

Not Illustrated—

## MODEL W-5 PROFESSIONAL 9-PLY WOOD SHELLS

Same general specifications with following stand substitutions:

- 800** Professional Hi-Hat Stand for 805 Deluxe.  
**803N** Two Professional Cymbal Stands for Two 703 Deluxe.  
**806** Professional Snare Drum Stand for 706 Deluxe.

See price list for possible substitutions of components, finishes and available mufflers.  
\*\*See Pearl System.



Washington Rucker • Bob Wilson  
Evan Diner • Rocky White • Jim Vaughn

# Pearl

DRUMS  
CONCERT TOMS

10



Shawn Howard

**MODELS** FG6802 HI-PITCH FIBERGLASS SHELLS  
FG3456 LO-PITCH FIBERGLASS SHELLS

**OUTFITS INCLUDE:**

**Model: FG6802**

- FG06 5" x6 Concert Tom, 913-1 clip bracket.
- FG08 5" x8 Concert Tom, 913-1 clip bracket.
- FG10 6" x10 Concert Tom, 913-1 clip bracket.
- FG12 8x12 Concert Tom, 913-1 clip bracket.
- FG111 Two Double Concert Tom Stands.

**Model: FG3456**

- FG13 9x13 Concert Tom, 913-1 clip bracket.
- FG14 10x14 Concert Tom, 913-1 clip bracket.
- FG15 12x15 Concert Tom, 913-1 clip bracket.
- FG16 14x16 Concert Tom, 913-1 clip bracket.
- FG111 Two Double Concert Tom Stands.



Frank "Chico" Guerrero • Roger Hawkins  
Chuck Flores • Frank Hudec • Steven Schaeffer

See price with possible substitutions of components. Availability subject to change.



The above sequence illustrates the wide dynamic range and continuous symmetry of a single attack and subsequent decay of the sound produced by Pearl Vari-Pitch. Due to

the symmetry and long decay time of a single attack, Vari-Pitch produces a readily discernible pitch whose quality more closely approximates that of other musical instruments.



*Shown in Gold Color*

Vari-Pitch is the answer to the player's need to have the versatility of a Roto-Tom with the depth and resonance of a conventional drum. For the first time a player can precisely select the balance between impact and resonance to create the sound needed. A few quick turns and the critical distance between head (generator) and shell (resonator) can be adjusted and locked into place with the exclusive drum stick receiver lock nut.

Once the balance between impact and resonance is selected and locked in, simply turn the head to the tension desired... high pitch, low pitch, wet sound, dry sound... or anything in between. It's all yours with Vari-Pitch.

With a Vari-Pitch Cannon, a different weight of batter head or even size of unit, will alter the response, sensitivity and feel of the Vari-Pitch Drum. The exclusive Vari-Pitch bracket allows interchanging of generating units among shells and will easily accommodate oversized units as well as smaller units to provide an even greater variety of sounds.

**MODELS VPC 1012 HI PITCH PHENOLIC SHELLS  
VPC 1416 LO PITCH PHENOLIC SHELLS**

**OUTFITS INCLUDE:**

**Model: VPC 1012**

- VPC10** 10" x10 Vari-Pitch Cannon, 8" Roto-Tom, 913-1 clip bracket.
- VPC12** 10" x12 Vari-Pitch Cannon, 10" Roto-Tom, 913-1 clip bracket.
- FG111** Double Concert Tom Stand.

**Model: VPC 1416**

- VPC14** 10" x14 Vari-Pitch Cannon, 12" Roto-Tom, 913-1 clip bracket.
- VPC16** 10" x16 Vari-Pitch Cannon, 14" Roto-Tom, 913-1 clip bracket.
- FG111** Double Concert Tom Stand.

See price list for possible substitutions of components, heads and available finishes.  
Check dimensions against Pearl Vari-Pitch Standard



Shown in Rosewood. Cymbals not included.

**MODEL F-16 FIBERGLASS SHELLS  
FW-16 FIBERGLASS LINED 9-PLY  
WOOD SHELLS\***

**OUTFIT INCLUDES:**

**Model:**

**222** Two 14x22 Bass Drums, Two 717-3 V.S.\*\* Double Tom Holder base plates, 720-R Hi-Hat to Bass Drum attachment, Two 786 Spurs, Two 732 internal felt muffler strips.

**FG06** 5 1/2x6 Concert Tom, 913-1 clip bracket  
**FG08** 5 1/2x8 Concert Tom, 913-1 clip bracket.  
**FG10** 6 1/2x10 Concert Tom, 913-1 clip bracket.  
**FG12** 8x12 Concert Tom, 913-1 clip bracket.  
**FG13** 9x13 Concert Tom, 913-1 clip bracket.  
**FG14** 10x14 Concert Tom, 913-1 clip bracket.  
**FG15** 12x15 Concert Tom, 913-1 clip bracket.  
**FG16** 14x16 Concert Tom, 913-1 clip bracket.

**212** 8x12 Tom Tom, 717-1 V.S. Tom bracket, 717-2 V.S. Tom arm, 734 muffler.  
**213** Two 9x13 Tom Toms, Two 717-1 V.S. Tom brackets, Two 717-2 V.S. Tom arms, 734 muffler.  
**214** 10x14 Tom Tom, 717-1 V.S. Tom bracket, 717-2 V.S. Tom arm, 734 muffler.  
**216** 16x16 Tom Tom, 781 legs, 734 muffler.  
**B4514** 5x14 Snare Drum, 734 muffler.  
**800** Hi-Hat  
**803N** Two Cymbal Stands  
**806** Snare Drum Stand  
**810** Two Bass Drum Pedals  
**FG111** Four Double Concert Tom Stands



Shown in Pure White. Cymbals not included.

**MODEL F-11 FIBERGLASS SHELLS (UPPER PHOTO)  
FW-11 FIBERGLASS LINED 9-PLY  
WOOD SHELLS\***

**OUTFIT INCLUDES:**

- Model:**  
**222** 14x22 Bass Drum, 786 Spurs, 732 internal felt muller strip.
- FG06** 5½x6 Concert Tom, 913-1 clip bracket.  
**FG08** 5½x8 Concert Tom, 913-1 clip bracket.  
**FG10** 6½x10 Concert Tom, 913-1 clip bracket.  
**FG12** 8x12 Concert Tom, 913-1 clip bracket.  
**FG13** 9x13 Concert Tom, 913-1 clip bracket.  
**FG14** 10x14 Concert Tom, 913-1 clip bracket.  
**FG15** 12x15 Concert Tom, 913-1 clip bracket.  
**FG16** 14x16 Concert Tom, 913-1 clip bracket.  
**216** 16x16 Tom Tom, 781 legs, 734 muller.  
**B4514** 5x14 Snare Drum, 734 muller.  
**800** Hi-Hat  
**803N** Two Cymbal Stands  
**806** Snare Drum Stand  
**810** Bass Drum Pedal  
**FG111** Four Double Concert Tom Stands

**MODEL F-9 FIBERGLASS SHELLS (LOWER PHOTO)  
FW-9 FIBERGLASS LINED 9-PLY  
WOOD SHELLS\***

**OUTFIT INCLUDES:**

- Model:**  
**222** 14x22 Bass Drum, 717-3 V.S.\*\* Double Tom Holder base plate, 786 Spurs, 732 internal felt muller strip.
- FG06** 5½x6 Concert Tom, 913-1 clip bracket.  
**FG08** 5½x8 Concert Tom, 913-1 clip bracket.  
**FG10** 6½x10 Concert Tom, 913-1 clip bracket.  
**FG12** 8x12 Concert Tom, 913-1 clip bracket.  
**212** 8x12 Tom Tom, 717-1 V.S. Tom bracket, 717-2 V.S. Tom arm, 734 muller.  
**213** 9x13 Tom Tom, 717-1 V.S. Tom bracket, 717-2 V.S. Tom arm, 734 muller.  
**216** 16x16 Tom Tom, 781 legs, 734 muller.  
**B4514** 5x14 Snare Drum, 734 muller.  
**800** Hi-Hat  
**806** Snare Drum Stand  
**803N** Two Cymbal Stands  
**810** Bass Drum Pedal  
**FG111** Two Double Concert Tom Stands

See price list for possible substitutions of components, heads and available finishes.  
\*All Concert Toms have fiberglass shells. \*\*Vari-Set System



Shown in Pure White. Cymbals not included

**MODEL F-7 FIBERGLASS SHELLS  
FW-7 FIBERGLASS LINED 9-PLY  
WOOD SHELLS\***

**OUTFIT INCLUDES:**

- Model:**  
**222** 14x22 Bass Drum, 786 Spurs, 732 internal felt muffler strip.  
**FG10** 6½x10 Concert Tom, 717-1 V.S.\*\* Tom bracket, 717-2 V.S. Tom arm.  
**FG12** 8x12 Concert Tom, 717-1 V.S. Tom bracket, 717-2 V.S. Tom arm.  
**FG13** 9x13 Concert Tom, 717-1 V.S. Tom bracket, 717-2 V.S. Tom arm.  
**FG14** 10x14 Concert Tom, 717-1 V.S. Tom bracket, 717-2 V.S. Tom arm.  
**216** 16x16 Tom Tom, 781 legs, 734 muffler.  
**B4514** 5x14 Snare Drum, 734 muffler.  
**800** Hi-Hat  
**803N** Two Cymbal Stands  
**989** Two V.S. Double Tom Floor Stands  
**806** Snare Drum Stand  
**810** Bass Drum Pedal



**MODEL F-624 FIBERGLASS SHELLS  
FW-624 FIBERGLASS LINED 9-PLY  
WOOD SHELLS**

**OUTFIT INCLUDES:**

- Model:**  
**224** 14x24 Bass Drum, 786 Spurs, 717-3 V.S.\*\* Double Tom Holder base plate, 732 internal felt muffler strip.  
**213** 9x13 Tom Tom, 717-1 V.S. Tom bracket, 717-2 V.S. Tom arm, 734 muffler.  
**214** 10x14 Tom Tom, 717-1 V.S. Tom bracket, 717-2 V.S. Tom arm, 734 muffler.  
**216** 16x16 Tom Tom, 781 legs, 734 muffler.  
**2118** 16x18 Tom Tom, 781 legs, 734 muffler.  
**B4514L** 6½x14 Snare Drum, 734 muffler.  
**800** Hi-Hat  
**803N** Two Cymbal Stands  
**806** Snare Drum Stand  
**810** Bass Drum Pedal

See price list for possible substitutions of components, heads and available finishes.

\*All Concert Toms have fiberglass shells. \*\*Vari-Set System



Shown in Pure White. Cymbals not included.

**MODEL F-524 FIBERGLASS SHELLS  
FW-524 FIBERGLASS LINED 9-PLY  
WOOD SHELLS**

**OUTFIT INCLUDES:**

**Model:**

- 224** 14x24 Bass Drum, 717-3 V.S.\*\* Double Tom Holder base plate, 786 Spurs, 732 internal felt muffler strip.
- 213** 9x13 Tom Tom, 717-1 V.S. Tom bracket, 717-2 V.S. Tom arm, 734 muffler.
- 214** 10x14 Tom Tom, 717-1 V.S. Tom bracket, 717-2 V.S. Tom arm, 734 muffler.
- 2118** 16x18 Tom Tom, 781 legs, 734 muffler.
- 4814L** 6½x14 Jupiter Snare Drum, 734 muffler.
- 800** Hi-Hat
- 803N** Two Cymbal Stands
- 806** Snare Drum Stand
- 810** Bass Drum Pedal



**MODEL F-420 FIBERGLASS SHELLS  
FW-420 FIBERGLASS LINED 9-PLY  
WOOD SHELLS**

**OUTFIT INCLUDES:**

**Model:**

- 220** 14x20 Bass Drum, 717-3 V.S.\*\* Double Tom Holder base plate, 814 Mini-Boom Cymbal Holder, 786 Spurs, 732 internal felt muffler strip.
- 213** 9x13 Tom Tom, 717-1 V.S. Tom bracket, 717-2 V.S. Tom arm, 734 muffler.
- 216** 16x16 Tom Tom, 781 legs, 734 muffler.
- B4514** 5x14 Snare Drum, 734 muffler.
- 800** Hi-Hat
- 806** Snare Drum Stand
- 810** Bass Drum Pedal



A



B



C

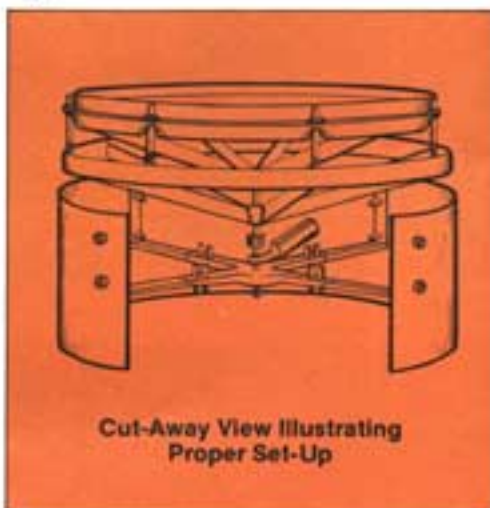
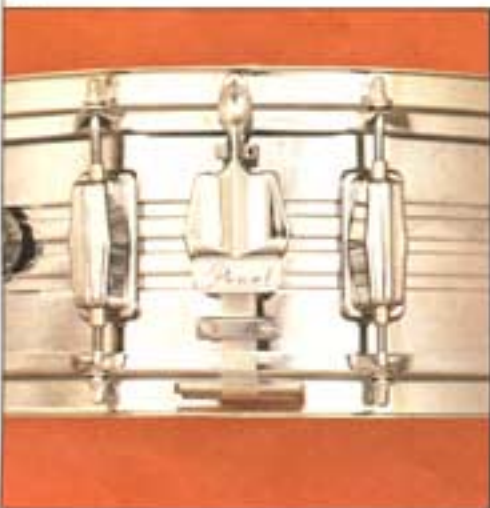

**A. Model 4814 Jupiter** (illustrated)—5" x 14" all purpose Snare Drum features 10 lugs, brass shell heavily chrome plated with parallel action strainer which releases both sides of snares simultaneously. Extended snares cover entire head for increased adjustability, sensitivity and response. Coated batter and clear snare Ambassador weight heads are standard. Internal tone control.

**Model 4814L Jupiter**—6 1/2" x 14" Rock Snare Drum. Other specifications as above.

**B. Model B4514** (illustrated)—5" x 14" all purpose Snare Drum features 10 lugs, brass shell heavily chrome plated with professional die cast throw off lever on strainer. Coated batter and clear snare Ambassador weight heads are standard. Internal tone control.

**Model B4514L**—6 1/2" x 14" Rock Snare Drum. Other specifications as above.

**Model D4514**—5" x 14" all purpose deluxe Snare Drum features 10 lugs, steel shell heavily chrome plated. Soundmaster weight heads are standard. Other specifications as above.

### Vari-Pitch

Vari-Pitch is the answer to the player's need to have the versatility of a Roto-Tom with the depth and resonance of a conventional drum. For the first time a player can precisely select the balance between impact and resonance to create the sound needed. A few quick turns and the critical distance be-

tween head (generator) and shell (resonator) can be adjusted and locked into place with the exclusive drum stick receiver lock nut.

Once the balance between impact and resonance is selected and locked in, simply turn the head to the tension desired... high pitch, low pitch, wet sound, dry sound... or anything in between. It's all yours with Vari-Pitch.

With a Vari-Pitch Snare Drum, a different weight of batter head or even size of unit, will alter the response, sensitivity and feel of the Vari-Pitch Drum. With any combination of changes, one basic Snare Drum can produce the delicate or piercing crispness of a piccolo Snare Drum... or the funkiest back-beat you'll ever need.

A note on tuning Vari-Pitch Snare Drums only. Because of the total venting inherent in Vari-Pitch, the usual relationship between snare and batter head tension may not apply. Many players have found that a greater than normal interval is a good starting point.

**C. Model VPS 514 Vari-Pitch** (illustrated)—5" x 14" all purpose Vari-Pitch Snare Drum features 8 lugs, phenolic shell with chrome covering, professional die cast throw off lever on strainer, 14" coated Ambassador weight head is standard. Movable "internal" tone control.

**Model VPS 614 Vari-Pitch**—6 1/2" x 14" Rock Vari-Pitch Snare Drum. Other specifications as above except 14" clear Emperor weight head is standard.

**Model VPS 1014 Vari-Pitch**—10" x 14" Hard Rock Vari-Pitch Snare Drum. Other specifications as model VPS 614.





A



C



B



D

#### A. Mounted Tom Toms\* (Shown in Walnut)

- Fiberglass shells: available in 8" x 12", 9" x 13", 10" x 14", 12" x 15" sizes. Complete with V.S.\*\* 717-1 bracket mounted, self aligning lugs, internal tone control. Coated Ambassador weight heads standard.
- Fiberglass-lined, 9-ply wood shells: as above excluding 12" x 15" size.
- 9-ply wood shells (W-series): available in 8" x 12", 9" x 13" sizes. Complete with V.S. 717-1 bracket mounted, self aligning lugs, internal tone control. Coated Soundmaster weight heads standard.

#### B. Floor Tom Toms (Shown in Silver Silk)

- Fiberglass shells: available in 14" x 14", 16" x 16", 16" x 18" sizes. Complete with self aligning lugs, bent shaped legs, internal tone control. Coated Ambassador weight heads standard.
- Fiberglass-lined, 9-ply wood shells: as above.
- 9-ply wood shells (W-series): available in 16" x 16" size only. Coated Soundmaster weight heads standard. Other specifications as above.

#### C. Concert Toms (Shown in Black Diamond)

- Fiberglass shells only: available in 5 1/2" x 6", 5 1/2" x 8", 6 1/2" x 10", 8" x 12", 9" x 13", 10" x 14", 12" x 15", 14" x 16" sizes. Complete with 913-1 clip bracket, self aligning lugs. Clear controlled sound heads with black dot standard.

#### D. Bass Drums (Shown in Marine Pearl)

- Fiberglass shells: available in 14" x 18", 14" x 20", 14" x 22", 14" x 24", 14" x 26" sizes. Complete with self aligning lugs, modern tymp handle rods, professional spurs mounted, internal felt muffler strip. Coated Ambassador weight heads standard.
- Fiberglass lined, 9-ply wood shells: as above excluding 14" x 26" size.
- 9-ply wood shells (W-series): available in 14" x 22" size only. Complete with self aligning lugs, T-handle rods, professional spurs mounted, V.S. 727-3 base plate mounted (not as illustrated... see pages 9 and 21), internal felt muffler strip. Coated Soundmaster weight heads standard.

\*Specify if mounted to player's right or left side \*\*Van-Set system  
See price list for available colors and model numbers.

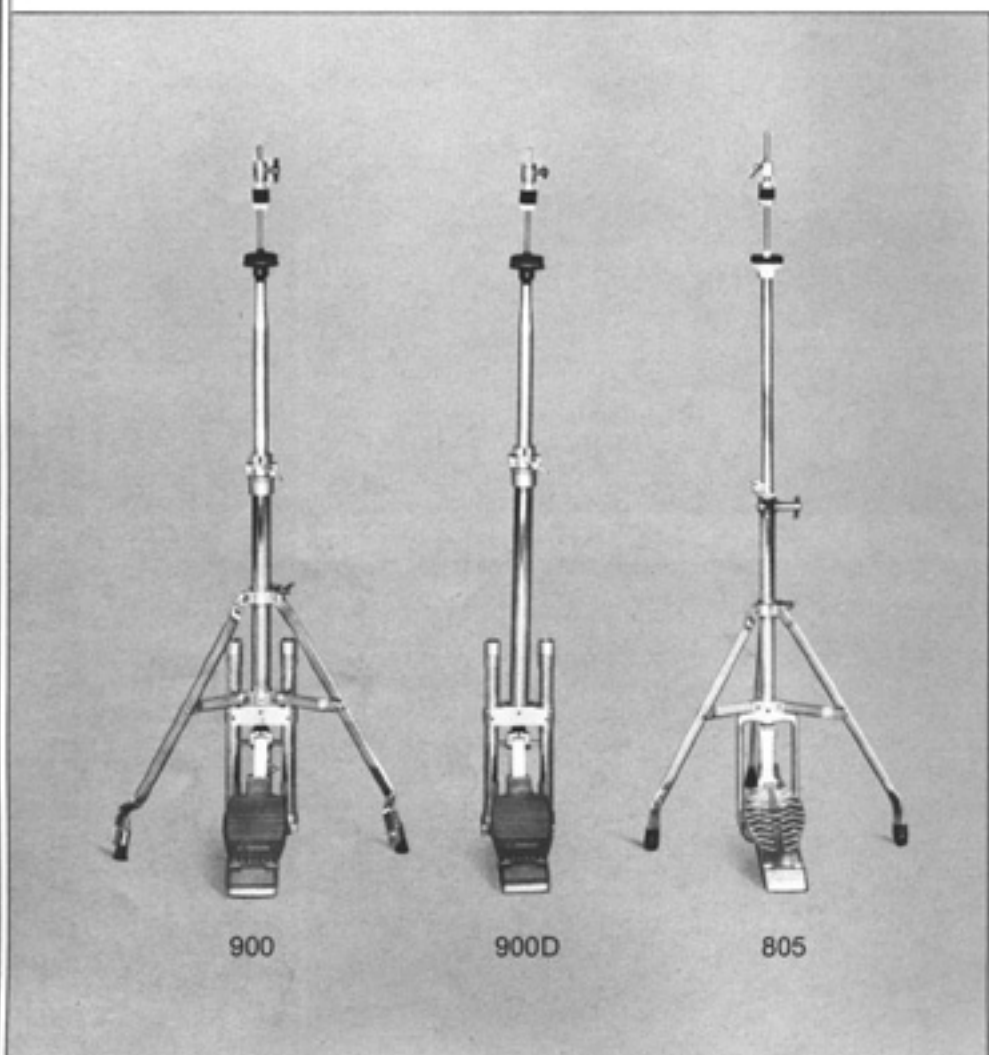

900

900D

805

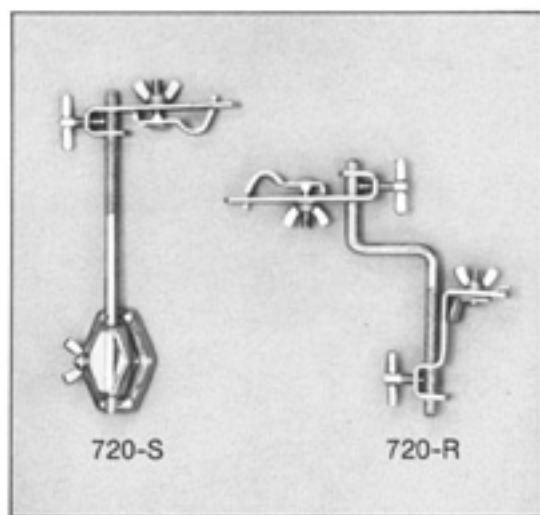

720-S

720-R

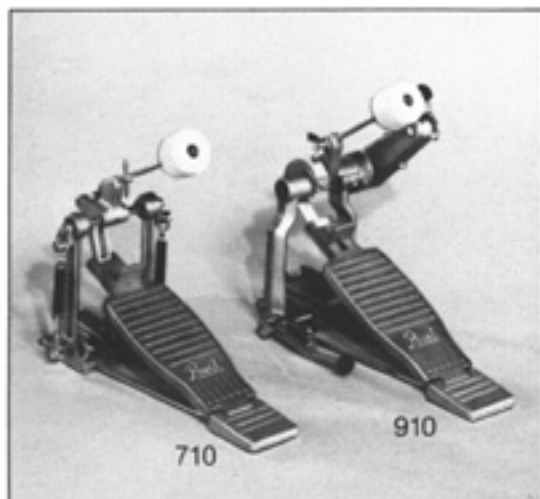

710

910

**Model 900 Hi-Hat**—Top adjusting parallel springs for speed, multiple potential tension adjustment and durability. Extremely smooth and quiet action. Reversible spurs on legs offer sharp point or rubber tip to prevent stand from slipping on any surface. Vari-Set lock remembers preferred height. Heavy duty top pull rod with posi-grip clutch. Heavily chrome plated.

**Model 900D Hi-Hat**—For double Bass Drum players. All features as above only without legs. Use with 720-R or 720-S Bass Drum to Hi-Hat attachment.

**Model 805 Deluxe Hi-Hat**—Direct pull, sturdy tri-pod base, built in spur to prevent creep, nylon bushing in height adjusting center section for positive grip, newly designed clutch and bottom cymbal cup with tilter. Heavily chrome plated.

**Model 720-R**—Hi-Hat to Bass Drum attachment for the double bass drummer allows positioning of the Hi-Hat Pedal as close as possible to the Bass Drum Pedal. Rim mount clamp.

**Model 720-S**—As above, only with a more permanent shell mount bracket.

**Model 910 Bass Drum Pedal**—An extremely sensitive yet durable pedal capable of adapting to any style of music. Unique compressed spring design is noiseless and fast. Tension can be adjusted even while playing. Instant and accessible locking mechanism holds pedal securely to Bass Drum. Case hardened steel shaft on beater, strap is nylon strip sandwiched between leather for strength and no stretch. Adjustable footboard with adjustable toe stop. Two built in spurs with rubber pad under heel plate prevents creep. Sandblast finish.

**Model 710 Bass Drum Pedal**—A deluxe double spring speed pedal in the same new sand blast finish as the model 910.

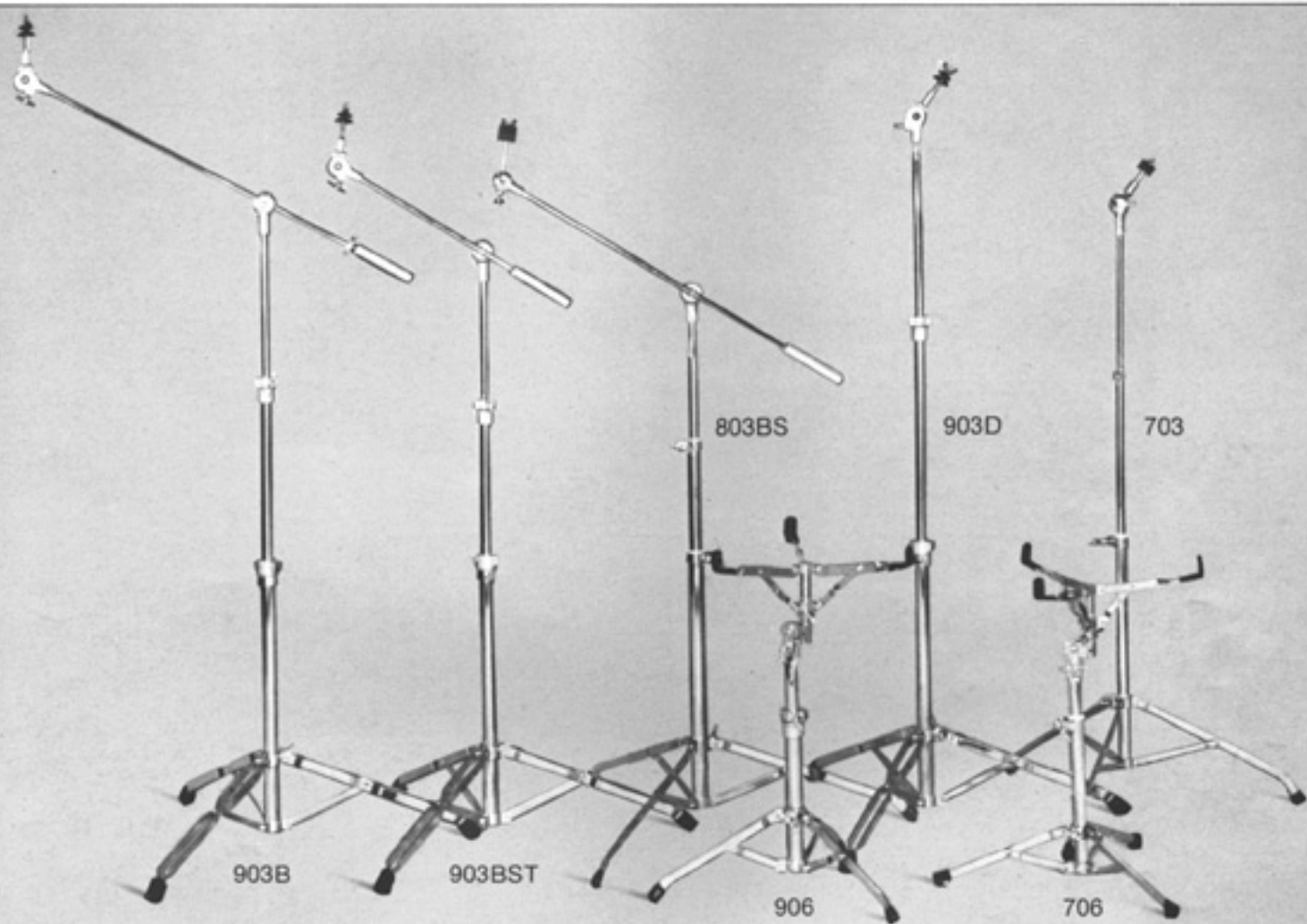

**Model 903B Boom Stand**—Sturdy, double braced legs, long boom arm with Vari-Set tilter and adjustable weight. Newly designed double tension height adjustment clamps will not slip (see insets). Heavily chrome plated.

**Model 903BST Short Boom Stand**—Same general specifications as 903B except boom arm is shorter and has a fixed weight.

**Model 803BS Boom Stand**—Single braced legs, long boom arm, nylon bushings in height adjustment joint prevent slip.

**Model 903D Cymbal Stand**—Double braced, wide spread legs offer excellent balance. Extra long sections for added height.

**Model 903 Cymbal Stand** (not illustrated)—Same general specifications as above only with single braced legs.

**Model 703 Deluxe Cymbal Stand**—Positive locking height adjustment with nylon bushings will not slip. Multi position tilter. Heavily chrome plated.

**Model 906 Snare Drum Stand**—Fully adjustable to any angle. Single braced legs. Large casing nut on arm tension adjustment positively locks stand to drum. Double tension

height adjustment clamp will not slip. Heavily chrome plated.

**Model 706 Deluxe Snare Drum Stand**—Fully adjustable to any angle. Single braced legs. Arm tension adjustment similar to 906. Heavily chrome plated.

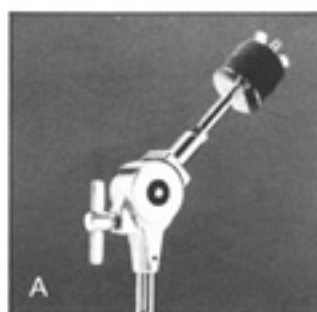

**A. Tilter**—Vari-Set principle as on tom tom holders. Easy to set angle up to 175 degrees. Will not slip.

**B. Die Cast Joints**—Double tension locking clamp eliminates loose joints and noise. Sand blasted with chrome finish.

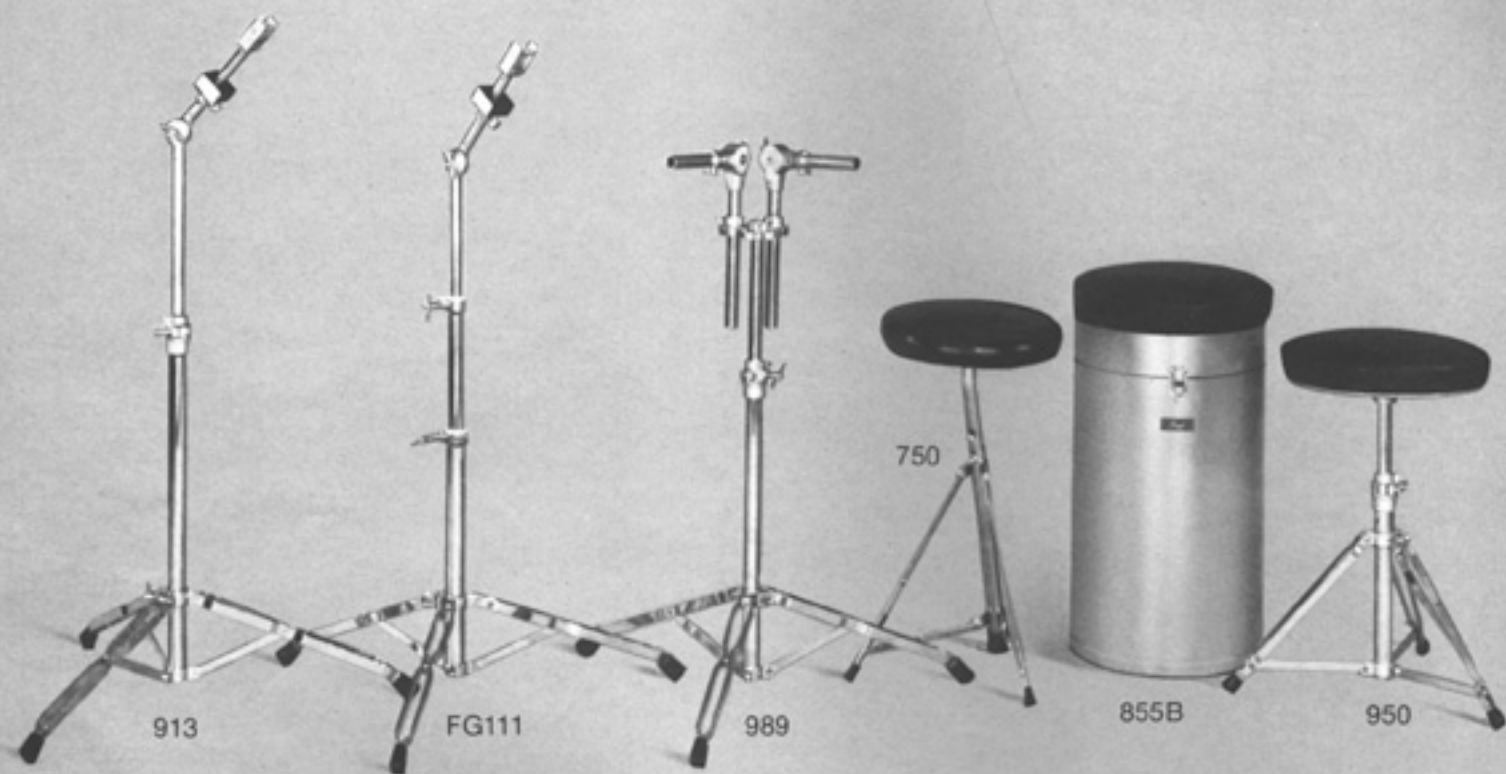

**Model 913 Double Concert Tom Stand**—Sturdy double braced legs with Vari-Set lock system. Felt lined wood spacer protects finish of drums. Will not slip. Used with drums having 913-1 clip type bracket mounted on them. Heavily chrome plated (see page 17).

**Model FG111—Concert Tom Stand**

Sturdy double braced legs. Lock-through tube with nylon bushing prevents twist and slip. Felt lined wood spacer protects finish of drums. Ratchet design tilter. Used with drums having 913-1 clip type brackets mounted on them. Heavily chrome plated (see page 17).

**Model 989 Double Tom Tom Stand**—Sturdy double braced legs with Vari-Set lock system. Complete with Vari-Set adapter and Tom Tom arms. Used with Tom Toms having V.S. 717-1 brackets mounted on them. Heavily chrome plated (see page 17).

**Model 950 Throne**—Widestance double braced legs, Vari-Set lock system on height adjustment and thickly padded, fully supported seat for playing comfort. Heavily chrome plated.

**Model 750 Deluxe Throne**—Rocket type, easy and positive height adjustment. Folds compactly for easy storage. Heavily chrome plated.

**Model 855B Throne**—Fixed height (25") barrel shaped throne opens for extra storage space. 13" diameter thickly padded seat for comfort, three clasps hold seat to base, strap handle to carry as a case. Specify color when ordering.

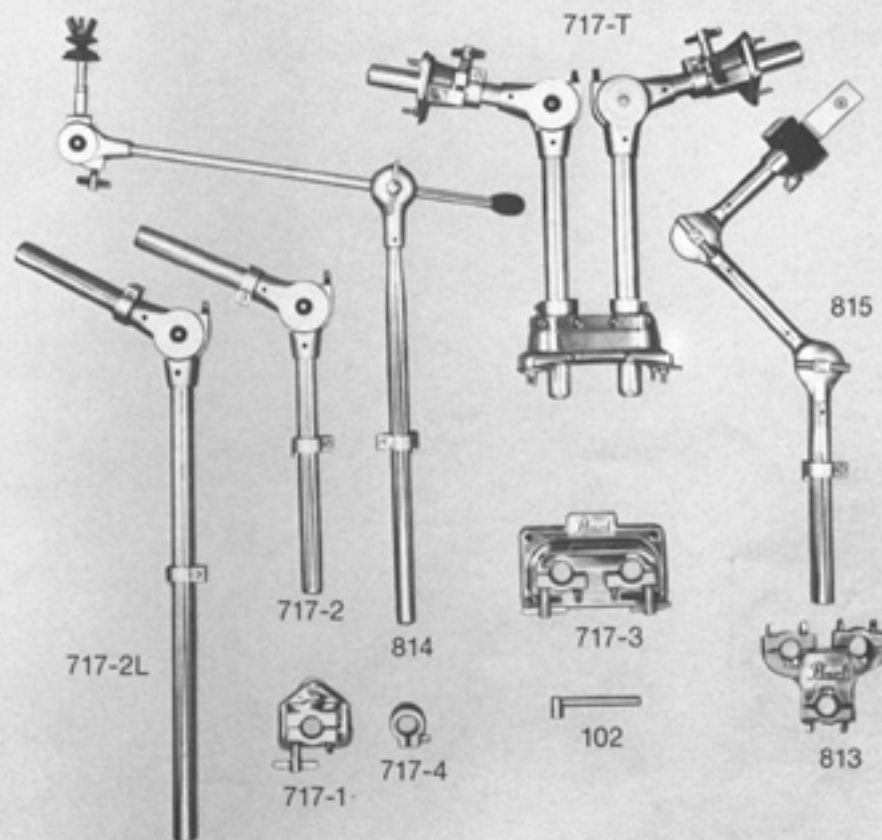
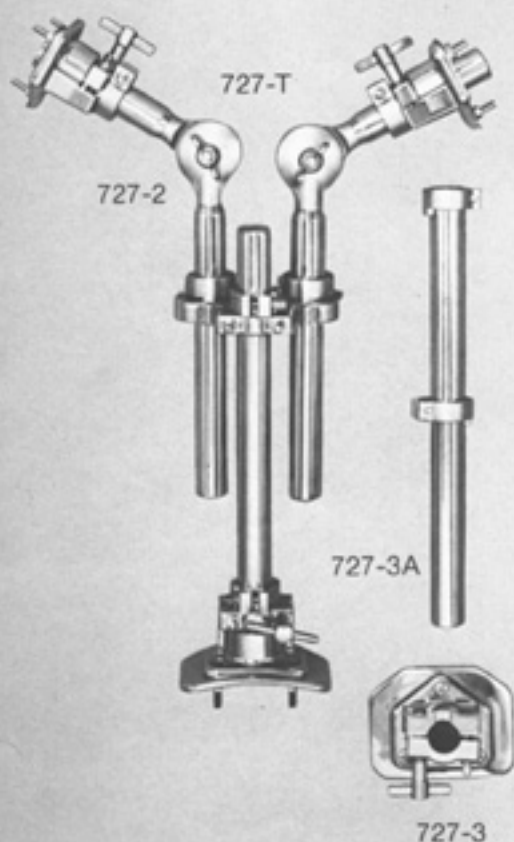

### TOM TOM HOLDERS

**Model 717-T Vari-Set System Double Tom Tom Holder**—Complete with Bass Drum plate, two arms, two Tom Tom brackets and four locks. Specify Bass Drum size when ordering.

**Model 727-T Double Tom Tom Holder**—Used on W-series, this holder utilizes the Vari-Set adapter, locks, and Tom Tom brackets. Fully compatible with the Vari-Set system.

### VARI-SET SYSTEM COMPONENTS AND ACCESSORIES

- Model 717-1** Tom Tom bracket, individual.
- Model 717-2** Tom Tom arm, individual with two V.S.\* locks.
- Model 717-2L** As above, with extra long bottom tube.
- Model 717-3** Bass Drum base plate, double receiver.
- Model 717-4** V.S. die cast lock.
- Model 102** V.S. right angle key.
- Model 813** V.S. adapter. Fits Tom Tom arms, Mini Boom, Concert Tom Holder.
- Model 814** Mini Boom Cymbal Holder with one V.S. lock. Fits adapter or Bass Drum base plate.
- Model 815** Double Concert Tom Holder with one V.S. lock and adjustable felt lined block. Fits adapter or Bass Drum base plate.
- Model 727-2** Tom Tom arm with two die cast locks.
- Model 727-3** Bass Drum base plate, single receiver.
- Model 727-3A** Single capped shaft with two V.S. locks.

Due to variations in shell construction and strength of competitive bass drums, Pearl and Norlin Music, Inc. cannot be responsible for damage resulting from non-factory installation of any Vari-Set units.

\*Vari-Set System

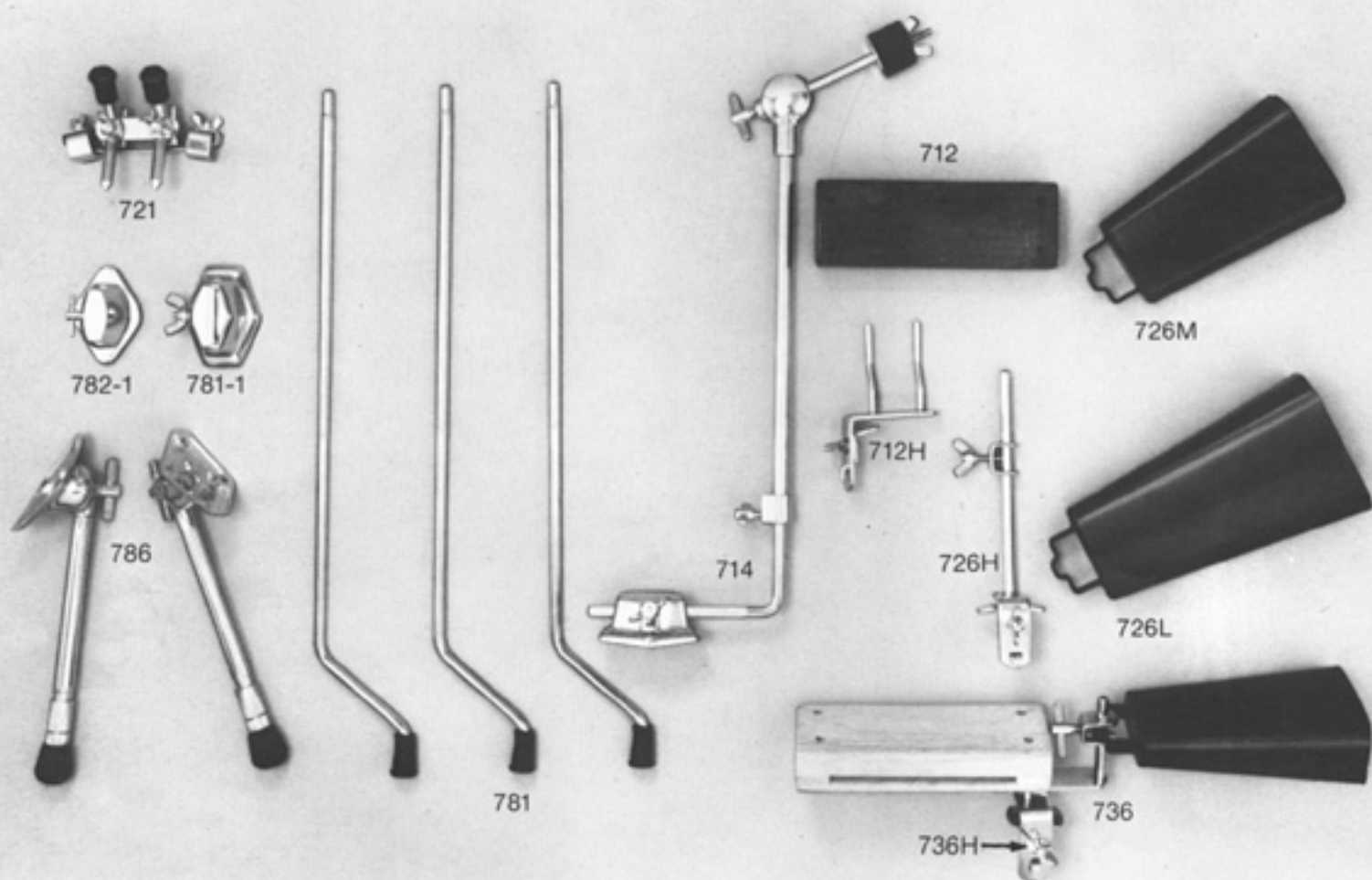

**Model 721 Anchor**—Mounts on front hoop of Bass Drum, reversible spur tips or rubber tips prevent creep on any surface.

**Model 786 Spurs** (pair)—Heavy duty, fully adjustable spurs fold against side of drum when not in use. Rubber tip or spur tip lock tightly in place on threaded shaft with two knurled lock nuts.

**Model 781 Tom Tom Legs** (set of 3 complete with brackets) Bent shaped legs, rubber tipped, knurled top section for positive grip in 781-1 bracket. 782-1 bracket used on W-series Floor Tom Toms.

**Model 714 Cymbal Arm**—L-shaped cymbal arm mounts to Bass Drum. Height adjustable with professional tilter.

**Model 726M Black 6½" Cowbell**

**Model 726L Black 8" Cowbell**

**Model 726H Holder**—Rim mount cowbell holder.

**Model 712 Wood Block**

**Model 712H Holder**—Rim mount single wood block holder.

**Model 736 Bell/Block Combination**—Black 6½" cowbell and wood block complete with rim mount holder.

**Model 736H Holder**—Combination wood block/cowbell rim mount holder only.

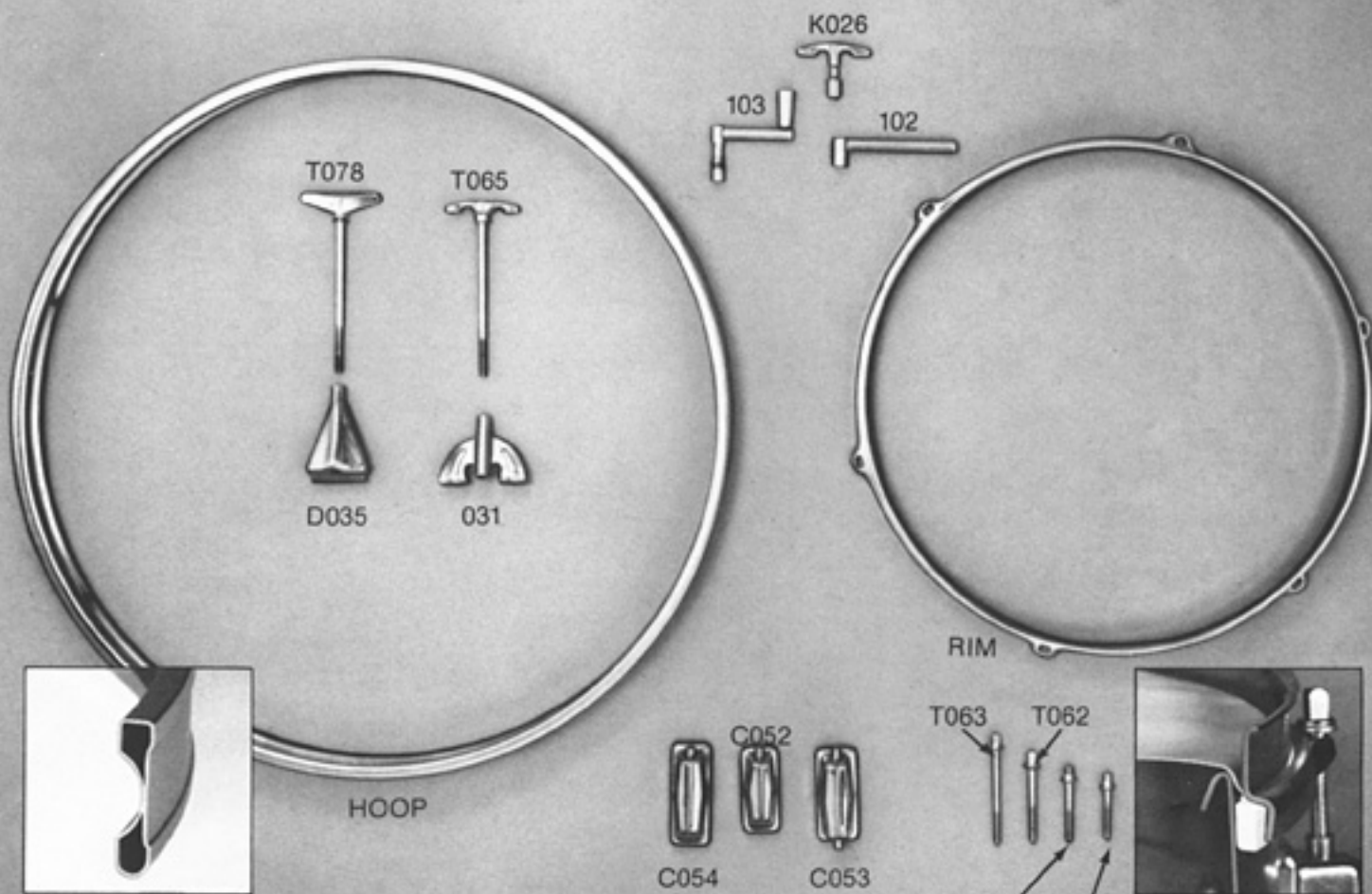

MODEL	DIA	HOLES	(TOP) BATTER	(BOTTOM) SNARE	CONCERT TOMS	TOM TOMS	BASS DRUMS	SNARE DRUM		
								JUPITER	REGULAR	VARI-PITCH
<b>HOOPS*</b>										
188D	18"	—	—	—	—	—	X	—	—	—
208D	20"	—	—	—	—	—	X	—	—	—
228D	22"	—	—	—	—	—	X	—	—	—
248D	24"	—	—	—	—	—	X	—	—	—
268D	26"	—	—	—	—	—	X	—	—	—
<b>RIMS**</b>										
064TT	6"	4	X	—	X	—	—	—	—	—
084TT	8"	4	X	—	X	—	—	—	—	—
106TT	10"	6	X	—	X	—	—	—	—	—
126TT	12"	6	X	—	X	X	—	—	—	—
136TT	13"	6	X	—	X	X	—	—	—	—
146TT	14"	6	X	—	X	—	—	—	—	—
148S	14"	8	—	X	—	—	—	—	—	X
148TT	14"	8	X	—	—	X	—	—	—	X
158TT	15"	8	X	—	X	X	—	—	—	—
168TT	16"	8	X	—	X	X	—	—	—	—
188TT	18"	8	X	—	X	X	—	—	—	—
1410B	14"	10	X	—	—	—	—	X	X	—
14100B	14"	10	X	—	—	—	—	X***	X***	—
1410S	14"	10	—	X	—	—	—	—	X	—
1410SJ	14"	10	—	X	—	—	—	—	X	—
14100S	14"	10	—	X	—	—	—	—	X***	—
14100SJ	14"	10	—	X	—	—	—	X***	—	—

\* Metal hoops, chrome plated with channel for matching color inlay. Specify color when ordering.  
 \*\* Metal, rim shot style, chrome plated  
 \*\*\* Die Cast

## DIE-CAST RIMS



SNARE



BATTER

MODEL	USE
<b>KEYS</b>	T060 All 5x14 Snare Drums, All V.P. Snare Drums (bottom & top)
	T061 All double headed Tom Toms, 6" thru 12" Concert Toms
	T062 All 6 1/2" x 14" Snare Drums (excluding V.P.), 13" and 14" Concert Toms
	T063 15" and 16" Concert Toms
	T065 W-Series Bass Drums
	T078 F & FW Series Bass Drums
<b>HOOPS</b>	D031 W-Series Bass Drums
	D035 F & FW Series Bass Drums
<b>LUGS</b>	C052 All Tom Toms, All V.P. Snare Drums (bottom)
	C053 All Snare Drums (excluding V.P.)
	C054 All Bass Drums
<b>KEYS</b>	102 Vari-Set Right Angle Key
	K026 Standard Drum Key
	103 Speed Key

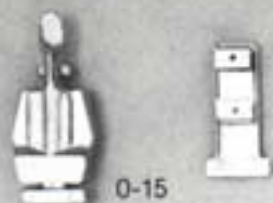

0-15



016



S-022



S-023



734



834



732

**Model 0-15—Professional Strainer**—Used on Pearl's Vari-Pitch and regular Snare Drums, the die-cast "gladstone" type throw-off lever is quick and quiet. Butt side as illustrated. Complete with all mounting hardware.

**S-022**—20 wire strands for above strainer complete with two plastic straps.

**Model 0-16—Jupiter Strainer**—Throw off and butt side for this super sensitive, parallel action strainer allow additional tensioning of the wire snares for fine tuning. Rod through drum shell releases both sides of snares simultaneously. Complete with all mounting hardware.

**S-023**—20 total wire strands in two equal banks provide a floating action for extra sensitivity.

**732**—Felt muffer strip as used on Bass Drums.

**734**—Internal tone control as used on Snare Drums and regular Tom Toms.

**834**—As above, only adapted for Vari-Pitch Snare Drum.



# Pearl

DRUMS

## CYMBALS/SETUPS/GLOSSARY

**"Z" SETUPS** Hand selected cymbals matched and pre-packaged at the Zildjian factory assure a perfect blend of sounds to meet a variety of musical styles. See glossary for additional information on type.

**Z-1 Basic Setup.** Two 14" New Beat Hi-Hats, One 20" Ride

**Z-2 Mini-Cup Setup.** Two 13" Mini-Cup Hi-Hats, One 16" Mini-Cup Crash, One 20" Mini-Cup Ride

**Z-3 Rock Setup.** Two 14" Rock Hi-Hats, One 18" Rock Crash, One 20" Rock Ride

**Z-4 Big Band Setup.** Two 14" New Beat Hi-Hats, One 18" Thin Crash, One 18" Medium Thin Crash Ride, One 20" Medium Ride

**Z-5 Hard Rock Setup.** Two 15" Rock Hi-Hats, One 17" Rock Crash, One 19" Rock Crash, One 21" Rock 21

### JAZZ/DANCE/ROCK

Weight	Type	Size Range
Thin	Splash	6" through 12"
	Fast Crash	14" through 18"
	Crash	13" through 20"
Medium	Crash	14" through 20"
	Thin	
Thin	Mini-Cup Crash	13" through 17"
	Rock Crash	16" through 19"
	Ride—Crash Ride	16" through 24"
	Swish—Ping	18", 20" and 22" only
	Flat Top Ride	14" through 22" (even sizes only)
Medium	Ride	18" through 24"
	Thin	
Medium	Mini-Cup Ride	18" through 22"
	Rock Ride	18" through 22"
	Flat Top Ride	14" through 22" (even sizes only)
	Ride—Ping	18" through 24"
Heavy	Mini-Cup Ride	18" through 22"
	Rock Ride	18" through 22"
	Flat Top Ride	14" through 22" (even sizes only)
	Ride—Ping	18" through 24"
Heavy	Mini-Cup Ride	18" through 22"
	Rock Ride	20" only
	Rock 21	21" only
	Flat Top Ride	14" through 22" (even sizes only)
Hi-Hat	Regular—Medium and Medium Thin	12" through 16"
	New Beat—Medium Top/Heavy Bottom	12" through 16"
	Rock—Heavy Top/Heavy Bottom	14" and 15" only
	Mini-Cup—Medium Mini-Cup Top/Heavy Bottom	13", 14" and 15" only
	Flange—Medium Heavy Top/Flanged Heavy Bottom	14" and 15" only
	Regular—Medium and Medium Thin	12" through 16"
	New Beat—Medium Top/Heavy Bottom	12" through 16"

### SYMPHONY/BAND/DRUM CORPS

Weight	Type	Size Range
Thin	Symphonic (La Mer)	12" through 16"
	Suspended	14" through 22"
Medium	Suspended	14" through 22"
	Thin	
Thin	Concert Band—Symphonic	16" through 24"
	French Style Pairs	18" through 24"
Medium	Suspended	14" through 22"
	Band	14" through 22"
	Concert Band—Symphonic	16" through 24"
	Vietnamese Style Pairs	18" through 24"
Medium	Hard Tined Suspended	14" through 22"
	Thin	
Heavy	Band	14" through 22"
	Concert Band—Symphonic	16" through 22"
Heavy	Band	14" through 22"
	Concert Band—Symphonic	16" through 22"
	Drum Corps	14" through 22"
	Germanic (Wagnerian) Style Pairs	18" through 22"

### GLOSSARY

**SPLASH CYMBALS** (Also called "Choke" Cymbals.) Small cymbals six through twelve inches in diameter and always thin in weight. Used for fast crash work and can be choked off very quickly.

**CRASH CYMBALS** (Jazz, Dance, Rock): Thin or medium thin cymbals, usually fourteen through twenty inches in diameter and struck one or more consecutive times to accent the beat.

**Thin Fast Crash Cymbals:** Slightly thinner in weight than regular Crash Cymbals—fast response, quick decay strong impact.

**Rock Crash Cymbals:** Available in 16" through 19" diameters, these cymbals are slightly heavier than regular Crash Cymbals and are designed to produce explosive crashes. Especially suited for Rock and amplified music.

**Mini-Cup Crash Cymbals:** Available in 13" through 17" diameters, these cymbals, with extra small bells, produce dry, "tight" crashes. Specially designed for small combo or studio work.

**CRASH RIDE CYMBALS** Always medium thin in weight, these cymbals run sixteen through twenty-four inches in diameter. Dual purpose cymbals, they are suitable for both crash work and for sustained ride cymbal playing.

**RIDE CYMBALS** (Jazz, Dance, Rock): Usually eighteen through twenty-four inches in diameter in various weights. Ride Cymbals are especially made to carry a sustained beat.

**Medium Ride Cymbals:** Always medium in weight, these are the most popular of all Ride Cymbals. Suitable for all types of music.

**Ping Ride Cymbals:** Always medium-heavy to heavy in weight. Especially made to produce a high pitched "Ping" sound, to allow positive stick control and to minimize spread. More precise definition than Medium Ride Cymbals.

**Flat Top Ride Cymbals:** Available in even sizes 14" through 22" diameter, these cymbals are designed with no cup or bell. Most popular sizes are the 18", 20" and 22". Positive, high pitched stick sound with virtually no buildup of overtones. Extremely popular for recording and small group work. Ride or Crash Ride only.

**Rock Ride Cymbals:** Available in two sizes, 20" and 21", these cymbals are heavier than regular Ride Cymbals, and with their deeper cups, will produce a strong bell sound with a dynamic ride beat.

**Rock 21 Cymbal:** Rock Ride Cymbal, in a special weight and with an extra deep cup, designed for the hard rock drummer. This cymbal enables the drummer to drive his band and generate tremendous power with less effort.

**Earth Cymbal:** A new dimension in sound. A Ride Cymbal with versatility. Can be used in a contemporary jazz group to pinpoint the beat (without overtones), yet has the penetrating power to project over the heaviest amplified rock music and the positive "ping" definition needed for recording sessions. One size—20"—with a large cup for bell work. Extra heavy in weight. Strictly a "beat" cymbal—not for crashing. This cymbal was purposely manufactured with a smooth, "earthy" like, "funky" looking finish, with no tonal grooves, in order to generate its unique sound "Organic" or "rustic" looking finish, unlike "normal" cymbals.



ZILDJIAN CO.  
MADE IN U.S.A.

25

**INDIVIDUAL CYMBALS** When ordering, consult weight table and glossary. Always specify size, weight and TYPE. (Model number is the letter "Z" followed by size.) Hi-Hat and hand cymbals are always shipped in factory matched pairs. See price list for additional charges on specific types and finishes.

### IZZLE CYMBALS:

Ride or Crash Ride Cymbals, sixteen through twenty-two inches in diameter, in which holes are drilled and rivets installed to give a sustained sizzling or buzzing type of cymbal sound.

### SWISH CYMBALS:

Available in even sizes only 16" through 24" in diameter. Most popular sizes 18", 20" and 22". Usually thin to medium in weight, with turned up edges. "Chinese" tonal characteristics. Rivets usually installed for a more sustained effect. Can be used as both Crash and Ride.

### PANG CYMBALS:

Available in 18", 20" and 22" diameters only usually medium-thin in weight and distinctively shaped for a sustained "Pangy" sound. Smaller than average cup and unique taper produces a "Bottom" sound of unusual depth and spread. 2 1/2" flat outer edge is ideal for installing rivets, if desired.

### HI HATS:

**Regular:** Two cymbals twelve through sixteen inches in diameter mounted one above the other on a cymbal stand controlled by a foot pedal. Factory matched on a basis of blend of tone and "chip" sound.

**Regular weights:** medium-thin to medium top and bottom. Many weight combinations are available.

**New Beat:** A special combination of medium weight top cymbal carefully matched with a heavy bottom for the intensified "chip" sound, extremely fast response, powerful projection and pinpoint definition preferred by the vast majority of modern drummers.

**Rock:** A unique combination of a heavy weight top cymbal and a heavy bottom cymbal matched and blended to provide the hard rock drummer with a strong, solid beat. Available in 14" and 15" diameters only.

**Mini-Cup:** Medium weight Mini-Cup top cymbal (small, shallow bell) and a heavy bottom cymbal specially matched for high pitched tonal qualities and "tight" stick sound. Available in 13", 14" and 15" diameters only ideal for small groups and recording.

**Flange:** An unusual pairing of a specially tapered medium-heavy top cymbal and a heavy bottom cymbal which has a 2" flanged outer edge. Available in 14" and 15" diameters only. Allows a drummer a full dynamic range with body and depth.

### SYMPHONIC HAND CYMBALS:

Paired cymbals, usually 18" through 22" in diameter to be used with straps or straps and pads (never wooden handles). Thin through heavy in weight. Three general tonal categories: (1) French, thin to medium-thin with a Swish attack; (2) Viennese, medium to medium-heavy with a Zzzing attack; (3) Germanic (or Wagnerian), heavy with a K-lang attack.

### BRILLIANTS:

A sparkling new innovation in cymbals, "Brilliant" are world famous Avedis Zildjian Cymbals furnished to an extremely high and reflective gloss by an exclusive patented process. "Brilliant" add color and flash to the performance of any marching band or drum corps and to rock and other pop music groups looking for unusual and spectacular visual effects. All Avedis Zildjian Cymbals and Gongs are available as "Brilliant" at a slight additional charge for this unique finish.

# Pearl

DRUMS

## DRUM HEADS

	Diam.	Pin Stripe Heads	CS Controlled Sound Heads				Coated Brushed Surface	Transparent Heads		
			Smooth White Black Patch	Smooth White Transparent Patch	Transparent Black Patch	Transparent Transparent Patch		Diplomat	Ambassador	Emperor
BATTER AND TOM TOM HEADS	6"	P306BE	R206-1	R206-2	R306-1	R306-2			306BA	306BE
	8"	P308BE	R208-1	R208-2	R308-1	R308-2			308BA	308BE
	10"	P310BE	R210-1	R210-2	R310-1	R310-2			310BA	310BE
	11"	P311BE	R211-1	R211-2	R311-1	R311-2			311BA	311BE
	12"	P312BE	R212-1	R212-2	R312-1	R312-2			312BA	312BE
	13"	P313BE	R213-1	R213-2	R313-1	R313-2			313BA	313BE
	14"	P314BE	R214-1	R214-2	R314-1	R314-2	R114-1		314BA	314BE
	15"	P315BE	R215-1	R215-2	R315-1	R315-2			315BA	315BE
	16"	P316BE	R216-1	R216-2	R316-1	R316-2			316BA	316BE
	17"	P317BE	R217-1	R217-2	R317-1	R317-2			317BA	317BE
	18"	P318BE	R218-1	R218-2	R318-1	R318-2			318BA	318BE
20"	P320BE	R220-1	R220-2	R320-1	R320-2			320BA	320BE	
SNARE HEADS	12"							112SD	112SA	112SE
	13"							113SD	113SA	113SE
	14"							114SD	114SA	114SE
	15"							115SD	115SA	115SE
	16"							116SD	116SA	116SE
	17"							117SD	117SA	117SE
18"							118SD	118SA	118SE	
BASS DRUM HEADS	18"	P318BB	R218B-1	R218B-2	R318B-1	R318B-2			318B	318BB
	20"	P320BB	R220B-1	R220B-2	R320B-1	R320B-2			320B	320BB
	22"	P322BB	R222B-1	R222B-2	R322B-1	R322B-2			322B	322BB
	24"	P324BB	R224B-1	R224B-2	R324B-1	R324B-2			324B	324BB
	26"	P326BB	R226B-1	R226B-2	R326B-1	R326B-2			326B	326BB
	28"	P328BB	R228B-1	R228B-2	R328B-1	R328B-2			328B	328BB
	30"	P330BB	R230B-1	R230B-2	R330B-1	R330B-2			330B	330BB
	32"		R232B-1	R232B-2	R332B-1	R332B-2				
	34"		R234B-1	R234B-2	R334B-1	R334B-2				
	36"		R236B-1	R236B-2	R336B-1	R336B-2				
40"		R240B-1	R240B-2	R340B-1	R340B-2					

Pearl drum heads are a product of Remo, Inc.—world's largest manufacturer of quality percussion accessories. Made to the same exacting specifications as Remo's Weather King heads, Pearl offers the most popular sizes, weights and types used by more of today's leading players. A Pearl head will make any drummer sound better, and there's a type to fit your own particular and distinctive sound requirements. Large familiar Pearl logo for front Bass Drum heads also available on reverse side for those players using only the back head. Specify when ordering.

**Pin Stripe Drum Heads**—Double deep, double dark, double mellow! Pin Stripes meet today's heavy drum sound 'head on' with a brand new two-ply construction that does its thing *naturally*. No more felts, tapes or artificial muffling—Pin Stripes give you that wet, flat funky sound that today's heavy-weight rock and jazz/rock performers demand. Two layers of selected Emperor-weight Dupont Mylar are bonded at the collar only with a special coating applied to provide a controlled muffle. The dampening effect goes well beyond that achieved by CS and FiberSkyn heads, and the sound and feel remain consistent over the entire playing surface.

**CS Black Dot Drum Heads**—The controlled, centered drum sound without undesirable "over ring!" The secret is the Sound Center—A special reinforcement that dampens most of the overtones but lets the fundamental drum tone come through loud and clear. Choice of smooth white or transparent film with either black or transparent Sound Center—plus a 14-inch brush-surface coated head with reverse side reinforcement.

Coated Heads				Smooth White Heads	FiberSkyn Heads		Sound Master Heads
Diplomat	Diplomat M5	Ambassador	Emperor		Ambassador	Med.	
106BD		106BA	106BE	206BA	506M	506T	
108BD		108BA	108BE	208BA	508M	508T	
110BD	110M5	110BA	110BE	210BA	510M	510T	
111BD	111M5	111BA	111BE	211BA	511M	511T	
112BD	112M5	112BA	112BE	212BA	512M	512T	1280
113BD	113M5	113BA	113BE	213BA	513M	513T	1380
114BD	114M5	114BA	114BE	214BA	514M	514T	1480
115BD	115M5	115BA	115BE	215BA	515M	515T	
116BD	116M5	116BA	116BE	216BA	516M	516T	1680
117BD	117M5	117BA	117BE	217BA	517M	517T	
118BD	118M5	118BA	118BE	218BA	518M	518T	
120BD		120BA	120BE	220BA	520M	520T	
							1450
		118B	118BB	218B	518BM	518BT	
		120B	120BB	220B	520BM	520BT	20SMB
		122B	122BB	222B	522BM	522BT	22SMB
		124B	124BB	224B	524BM	524BT	24SMB
		126B	126BB	226B	526BM	526BT	
		128B	128BB	228B	528BM	528BT	
		130B		230B	530BM	530BT	
		132B		232B	532BM	532BT	
		134B		234B	534BM	534BT	
		136B		236B	536BM	536BT	
		140B		240B	540BM	540BT	



**Transparent Heads**—Transparent heads provide “see-through” excitement, or can be painted on the underside for a custom look. They are especially in demand in the medium Ambassador and heavy-duty Emperor head weights for rock bands and marching units. Available in a full range of sizes from 6” to 20” diameter and also in Bass Drum heads from 18” to 30” diameter.

**Snare Side Heads**—Snare Side Heads are available in three weights on specially-selected films designed to vibrate freely, providing maximum snare sound. Furnished in sizes from 12” to 18” in diameter.

**Coated Heads**—The standard of excellence for more than a decade! Coated heads feature the exclusive long-lasting coated surface which provides crisp brush and stick response for the life of the head. A complete range of batter and Tom-Tom in three weights—Diplomat, Ambassador and Emperor—plus the very thin Diplomat M5 heads specially developed for sensitive orchestral percussion. Bass Drum heads furnished in either Ambassador or heavy duty Emperor weights.

**Smooth White Heads**—Ideal for Tom Toms, marching drums or wherever a coated surface is not required, these heads are made of a smooth surface white film which can be wiped clean with a damp cloth. Available in three weights, including the heavy-duty Emperor heads with improved pull-out protection for drum corps use.

**FiberSkyn Drum Heads**—The FiberSkyn sound is darker, rounder, warmer than other plastic heads... softer, more mellow and with very little ring. FiberSkyn heads are created by bonding a thin, lightweight fiberglass fabric to selected plastic film, using a unique laminating process. The result is an excellent brush surface with good “feel,” consistent sound and fine performance in all sizes. FiberSkyn heads are available in both Medium and Thin headweights.

**Sound Master Heads**—Sound Master drum heads were designed with functional economy in mind. Constructed of strong, weatherproof plastic with reinforced epoxy hoops, they give fine-sounding performance at surprising low cost. Their tonal qualities and all around performance make them ideal multi-purpose drum heads.



Tuneable Practice Pads give you a true drum feel without the excessive drum sound. Play the edges, play the centers or play the entire drum surface. You can hear all the differences in dynamics when you play loud and soft. The practice pads are complete with tensioning key, warranty and an instruction booklet.

The versatile Drum Practice Sets are the choice of leading professionals. You can recreate the exact feel of your own drum set because each rugged practice set is fully adjustable.

Newly designed Roto-Toms offer an extremely wide range from bongo to timpani. Simply rotate the drum to tune it. The new cast aluminum tension support frame gives rugged strength plus a free flow of sound.

Timpani Roto-Toms—Extended range for each Roto-Tom is a full octave or more. Stands not included.

<b>Model RR6T</b>	6" dia. e <sup>1</sup> /c <sup>2</sup>	<b>Model RR14T</b>	14" dia. G/e
<b>Model RR8T</b>	8" dia. g/e <sup>1</sup>	<b>Model RR16T</b>	16" dia. F/d
<b>Model RR10T</b>	10" dia. c/a	<b>Model RR18T</b>	18" dia. E/c#
<b>Model RR12T</b>	12" dia. B/g		

#### CS ROTO-TOMS

Furnished with transparent head and black sound center. Stands not included.

<b>Model RR6</b>	6" diameter	<b>Model RR14</b>	14" diameter
<b>Model RR8</b>	8" diameter	<b>Model RR16</b>	16" diameter
<b>Model RR10</b>	10" diameter	<b>Model RR18</b>	18" diameter
<b>Model RR12</b>	12" diameter		

#### ROTO-TOM STANDS

**Model 102RT** Holds single drum, 6" to 12" size, light weight

**Model 103RT** Holds single drum, 6" to 18" size, heavy duty (illustrated above)

**Model 104RT** Holds double drums, any two sizes, heavy duty (illustrated above)

#### Practice Sets

**Model RPS10** standard 4 piece set (illustrated)—contains 6" pad (Bass Drum) 8" pad (Tom Tom) two 10" pads with extension support rods (Snare and Floor Tom Tom), cymbal arm, center support assembly

**Model RPS10T** twin Tom 5 piece set—As above with one additional 8" pad to duplicate two mounted Tom Toms.

**Model RPS10D** Double Bass Drum set—identical to RPS10 with one additional 6" pad with separate base plate and center support.

#### Practice Pads

**Model RT6** 6" diameter

**Model RT8** 8" diameter (illustrated with 101RT stand)

**Model RT10** 10" diameter



**Model FC210 QUINTO**—10" diameter  
**Model FC211 CONGA**—11" diameter  
**Model FC212 TUMBA**—12" diameter

Accurately proportioned head-to-belly taper on the Quinto, Conga and Tumba combined with sturdy fiberglass construction allow more projection of an authentic Latin American sound. Chrome plated hardware. Telescopic rubber tipped legs adjust to the exact height you prefer. Available in black or white.

#### **Model B213 TIMBALES**

Brass shells, brightly chrome plated, give these timbales a more authentic sound. The brass increases the projection of the 6½" x 14" and 6½" x 13" shells. Complete with sticks, a 6½" black cowbell mounted on heavy duty fully adjustable stand.

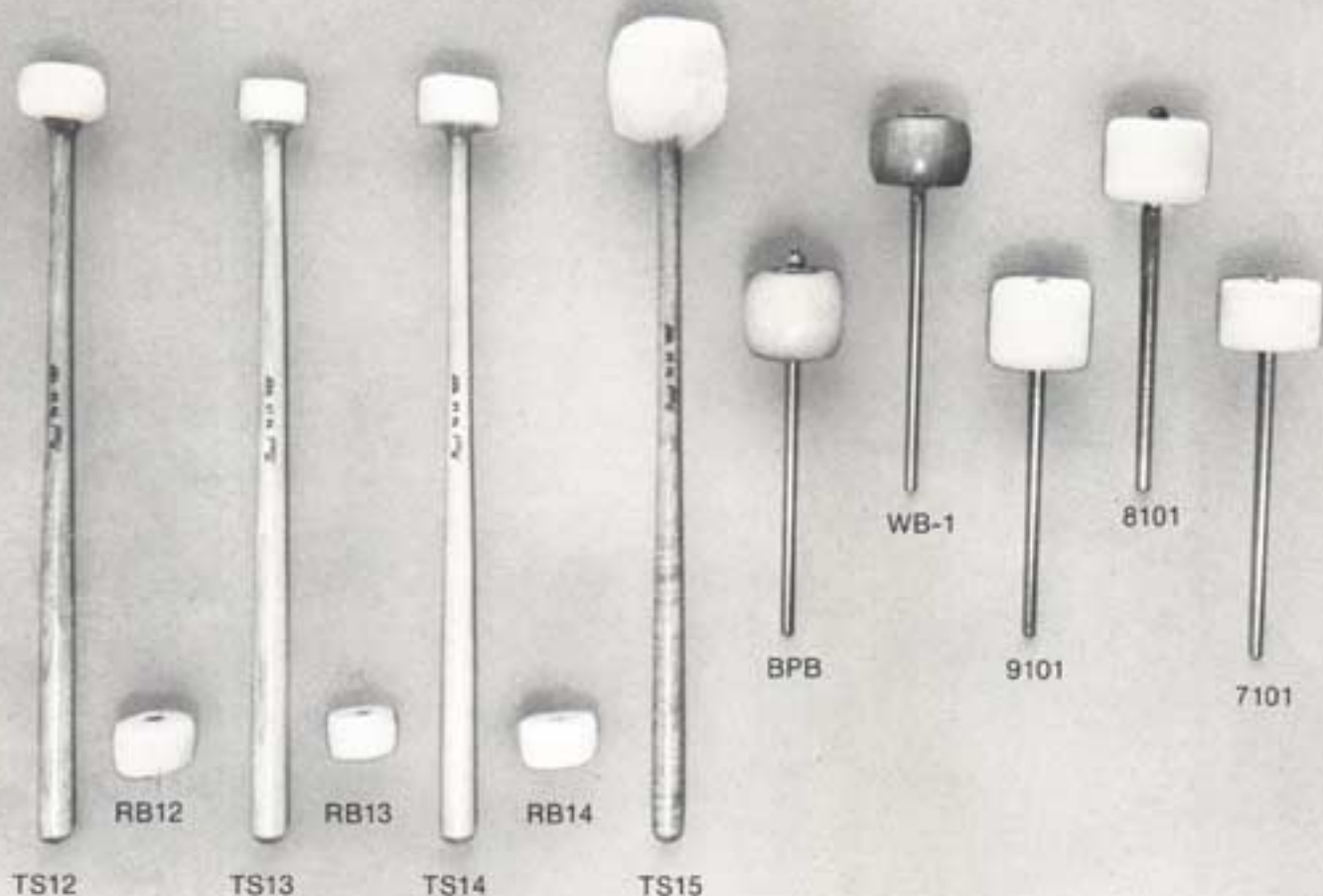

A selection of popular sizes to meet most playing requirements. Replacement balls are available for models 12, 13 and 14 on the Pearl mallets. Pearl stick necklaces and belt buckles are packaged in plastic presentation boxes.

**TS12** Large all purpose model, mild Spanish felt heads, good on Tom Tom, Tympani and Cymbals

**RB12** Replacement Ball

**TS13** Professional model with small Spanish felt cartwheel head covered with hand sewn finest piano felt.

**RB13** Replacement Ball

**TS14** Professional model with large Spanish felt cartwheel head covered with hand sewn finest piano felt.

**RB14** Replacement Ball

**TS15** Conventional lambswool orlon covered heads, hand-made.

**BPB** Wooden ball end beater, large

**9101** White, hard felt, large ball end beater. Case hardened shaft.

**8101** White, hard felt, medium ball end beater

**7101** White, hard felt, small ball end beater

**WB-1** Wooden ball end beater, medium



**Silver Stix.** The grooviest in demand hang-ups ever. Pearl silver drum stick necklaces.

**Belt Buckle.** Pearl logo on brass belt buckle.

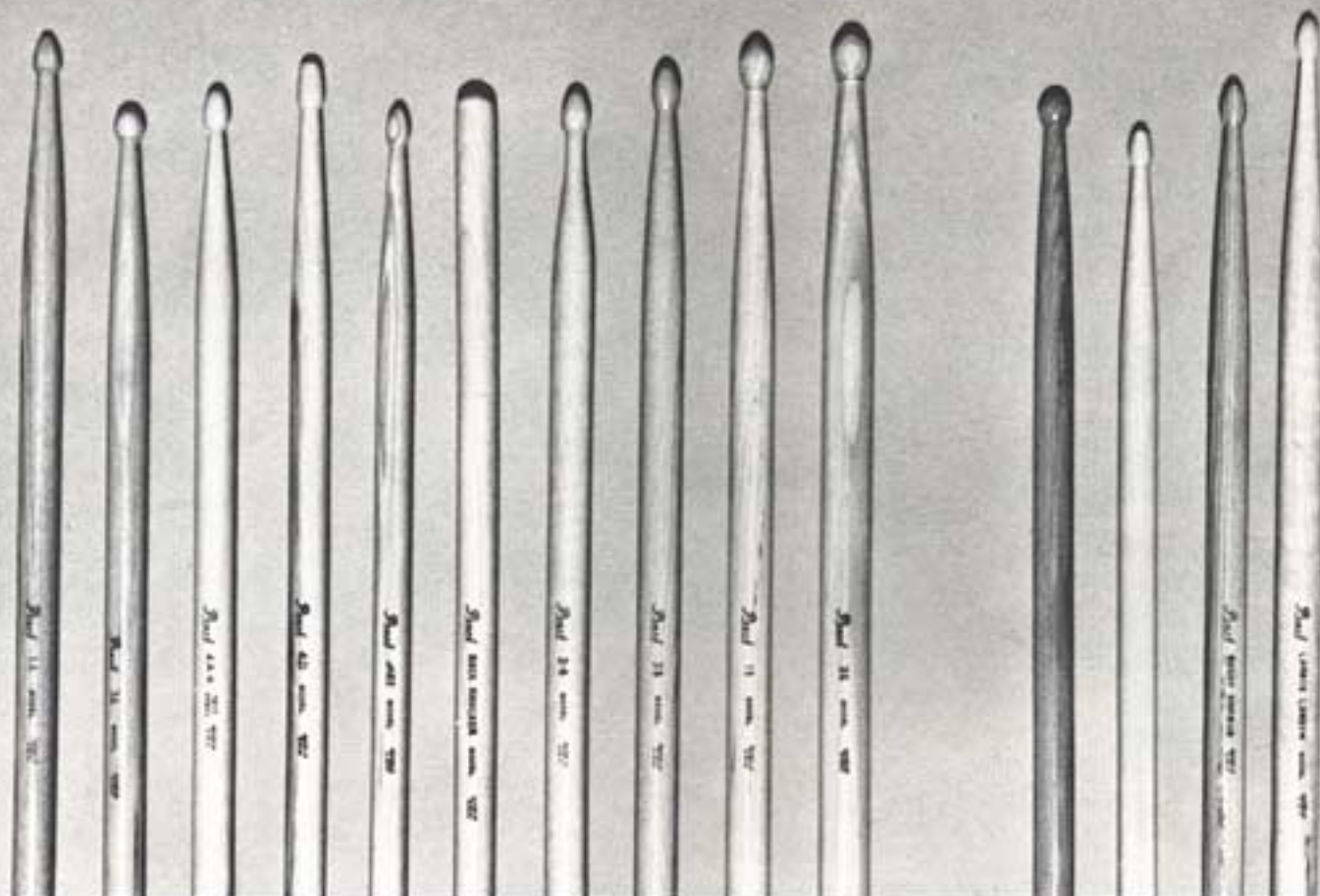

1A 3A 4A 4D JAZZ ROCK 2B 5B 1S 3S 707 7A 5A LL  
KNOCKERS

The finest domestic select grained hickory obtainable is used to produce this selection of the more popular styles and sizes as used by most players. When ordering those models offered with nylon tips, add letter "N" to model number.

An ideal way to keep your store name in front of your drum stick customers every day!

MODEL	DIAMETER	LENGTH	WOOD	TIP	
				WOOD	NYLON
1A	5/16"	16"	X		X
3A	5/16"	15 1/2"	X		X
4A	5/16"	16"	X		X
4D	5/16"	16"	X		X
JAZZ	17/32"	15 7/8"	X		
ROCK	17/32"	15 7/8"	X		
KNOCKERS	5/16"	16"	X		
2B	5/16"	16"	X		
5B	5/16"	16"	X		
1S	5/16"	17"	X		
3S	5/16"	17"	X		
707	5/16"	16"	X		X
7A	5/16"	15 1/4"	X		X
5A	5/16"	16"	X		X
LL	5/16"	17"	X		X



For a small additional charge Pearl will manufacture for you any of the above models (personalized) with either your name or your store's name bracketed by the Pearl logo and model number. Imprints are limited to 23 characters.

To order Pearl custom personalized drum sticks include the letter CP in front of the model numbers listed above. Minimum order is 100 pairs of the same model. Please specify exact spelling on personalized sticks and include a sample if possible.

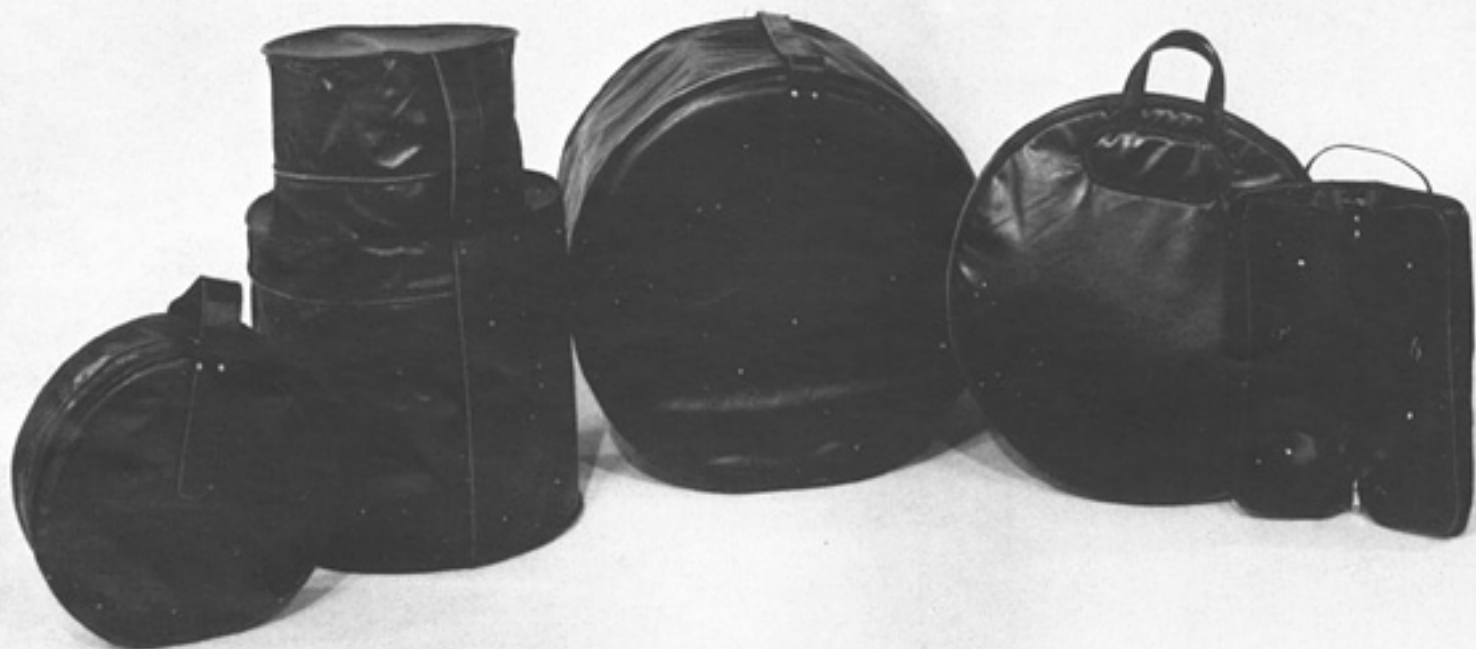

Pearl's jet black covers are made with plyhide. It's a thick man-made material that's water-repellent, and almost impossible to tear. The brass zippers are extra strong and the plyhide's attractive leather grain resists wrinkles. Balanced riveted handles on all cases are designed to distribute the weight of the drum from the center of the cover.

#### Bass Drum Covers

1418CV 14" x 18"  
1420CV 14" x 20"

#### Snare Drum Covers

514CV 5" x 14"

#### Tom Tom Covers

812CV 8" x 12"  
913CV 9" x 13"  
1014CV 10" x 14"

1422CV 14" x 22"  
1424CV 14" x 24"

614CV 6½" x 14"

1414CV 14" x 14"  
1616CV 16" x 16"  
1618CV 16" x 18"

#### 3522 Cymbal Pouch

Convenient carrying pouch for cymbals has a sturdy brass zipper, double reinforced to prevent cymbals from cutting through the material. Features inside pocket for extra equipment. Holds cymbals up to 22" in diameter.

#### 1650 Stick Bag

Plyhide stick and mallet bag attaches to tom tom or mallet instrument while playing to keep your gear handy. Features extra sturdy elastic straps, strong zipper and extra gadget pockets inside and out.

**How to Order Covers & Cases**—Covers and cases are made with allowance for lugs, rods and counter hoops. Measure across head inside of hoop. Measure shell height from one head surface to the other. Always give shell size only.



Heavy, first grade CH fibre board used in the new Pearl case line. Each case lacquer treated to help prevent warping from moisture. All joints are riveted and the extra wide, multiple straps with large buckles add even more protection.

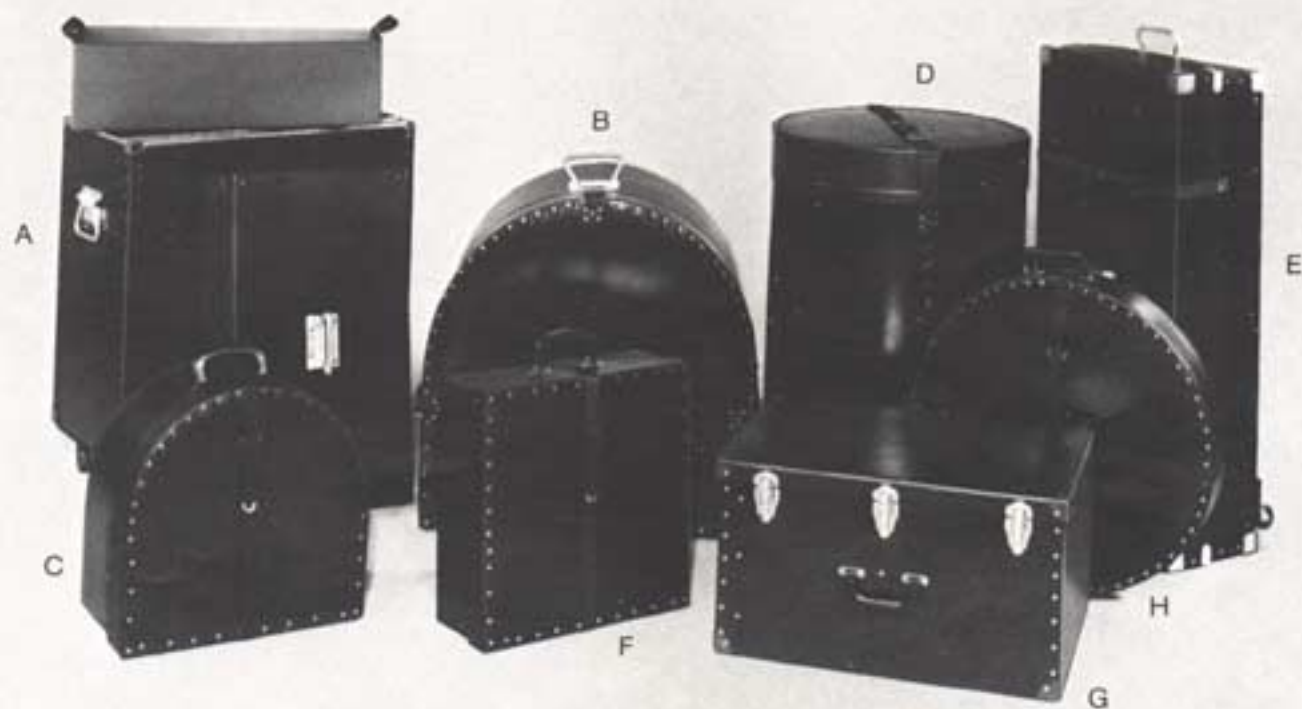

### A—Trap Cases

#### 1460 Carry-All Trap Case

Extra width allows for extra accessories. Cymbals up to 22" and 6½" x 14" snare drum compartments. Wide wrap around straps, heavy duty steel chest handles and super strong metal corners. Dimensions: 23" x 11½" x 22½" High. Tray—22" x 8" x 7" Deep

1460W Carry-All Trap Case as above—with wheels

#### 1480 King Size Trap Case

Extra wide and extra long. The extra length allows for up to 24" cymbals and heavy duty stands. Extra width means room for more accessories. Has all the fine construction qualities as the carry-all trap case, plus 3" heavy duty casters bolted to ½" caster board. Dimensions: 25½" x 14½" x 25" High. Tray—24" x 11" x 6½" Deep

### B—Bass Drum Cases

1108 14" x 18"      1110 14" x 22"      1118 14" x 26"

1109 14" x 20"      1117 14" x 24"

### C—Tom Tom Cases

1408 8" x 12"      1411 16" x 16"      1415 12" x 15"

1409 9" x 13"      1412 10" x 14"

1410 14" x 14"      1414 16" x 18"

### D—Combination/Barrel Throne/Conga

1289 8" x 12"/14" x 14"

1416 9" x 13"/16" x 16" (Also holds 8 nested concert toms)

1290 8" x 12"/9" x 13"

1291 9" x 13"/10" x 14"

1417 10" Quinto-15" Dia., 30" High

1418 11" Conga-16½" Dia., 30" High

1419 12" Tumba-17½" Dia., 30" High

1800 Barrel Throne

### E—Giant Heavy Duty Stand Case

#### 1475W Heavy Duty Stand Case

This case will accommodate longer boom stands and many other items with a minimum of tear-down. Features fibre strategically reinforced with plywood, heavy duty metal handles and locking latches. Two sturdy fixed wheels. Dimensions: 37" x 11" x 17"

### F—Snare Drum Case

1514 5" x 14"      1614 6½" x 14"

### G—Snare Drum Accessory Case

#### 1465 Standard Fibre Snare Drum Case

This case will hold up to a 10" x 14" snare drum plus gadgets. Also accommodates Vari-Pitch snare drum models VPS514 or VPS614. Dimensions: 22½" x 16" x 13" High. Tray—22" x 15¼" x 2¼" Deep.

#### 1466 Vari-Pitch Cannon Fibre Case—High Set

This case will hold the VPC10 and VPC12 Cannons with a compartment for the double stand.

#### 1467 Vari-Pitch Cannon Fibre Case—Low Set

This case will hold the VPC14 and VPC16 Cannons with a compartment for the double stand.

### H—Cymbal Caddy

#### 1490 Cymbal Caddy

Carry as many as 10 cymbals safely and securely in this fibre case—the same strong material used in drum cases. A steel center peg firmly holds up to 10 cymbals (maximum diameter 22").



Pearl is very active in the percussion clinic field and offers a unique approach to educational clinics and fund raising concerts through the widely diversified talents of those fine players using Pearl drums.

Each clinician is an acknowledged leader in his field and offers a fresh, contemporary approach to make each clinic a memorable and meaningful presentation. Choose the artist that specializes in your particular needs and let us help you put your clinic together.

Complete details on Pearl Clinicians are available to educational organizations, institutions and authorized Pearl dealers. Send for your copy of "Pearl Clinicians" today.



- 895514** **Latin Sounds From The Drum Set** by Frank "Chico" Guerrero. Cuban and Brazilian rhythms and instruments are explained in detail.
- 895530** **Musicians Guide to Polyrhythms—Vol. 1** by Pete Magadini. A practical method to develop polyrhythmic techniques.

- 895812** **Musicians Guide to Polyrhythms—Vol. 2** by Pete Magadini. A method to extend the musical knowledge and sensitiveness of the contemporary musician by developing polyrhythmic techniques.
- 895813** **The Spirit of Independence . . . Rock and Jazz Time for Drummers** by Jim Engle.
- 895814** **Salsa Rock** by Johnny Sciarrino. A complete guide for blending the drum set with the Latin Rhythm section.
- 895541** **Independence for the Beginner—Vol. 1** by Chuck Flores. Designed to develop greater flexibility on the drum set.
- 895542** **Independence for the Beginner—Vol. 2** by Chuck Flores. A continuation of volume 1.
- 895515** **Gamut** by Randy May. A study in equalizing single strokes, double strokes and paradiddles artistically and musically around the drum set with simultaneous footwork.



- 895539** **Bass Drum Control** by Colin Bailey. Develops bass drum technique for increased solo flexibility.
- 895537** **Progressive Studies for Double Bass Drums** by Louis Bellson. Designed to develop double bass drum flexibility and control.
- 895816** **Hand to Foot, Foot to Hand Drum Pattern** by Jim Engle. Patterns for rock or jazz solos.
- 895817** **Beginning of Time** by Jim Engle. A beginning to intermediate study.
- 895818** **Big Time** by Jim Engle. A study in big band drumming and drum beats of the world.



- 895520** **All Kinds of Rock** by Jim Engle. Unique design lets you group 159 different drum patterns into any combination of three that you want.
- 895521** **Rock 'N Time** by Jim Engle. Fills and solos for all styles of rock.
- 895523** **Rock-Jazz Phrasing** by Henry Bellson. For the advanced drummer.
- 895522** **Jazz-Rock Fusion** by Les DeMerle. Exposes the player to the coordination and endurance involved in today's music.



The fine players shown in this catalog are representative of the ever increasing numbers of pros around the world who have come to expect more from Pearl. Pearl has always responded to players needs by delivering the sound and durability they demand. In return, Pearl has earned their seal of approval as "player designed." Their professional suggestions along with those from an enthusiastic and knowledgeable network of music dealers help keep Pearl ahead of the ever changing and varied trends from coast to coast.

PHOTOS READ FROM LEFT TO RIGHT

- TOP ROW—Mark Van Dyck • Keith Killgo • Don Williams • Charles Perry • Al Schneider • Ed Poudrier  
 2ND ROW—Vincent Ruggiero • Wally Snow • Dale Sweetland • Logan Swords • Mark Hynes • John Ballard  
 3RD ROW—Bobby Goldman • Rick Custodio • Ron Howden • Chuck Piscitello • Richard Pidanick • Bill Nawrocki  
 4TH ROW—Si Edwards • Joe Corsello • Lloyd Cranford • Ralph Forbes • Bart Hall • Chic Colburn  
 5TH ROW—Sy Friedman • Joey Vespe • Raphael Duenas • Dave Howard • Bill Harris • Tom Horst  
 6TH ROW—Bob Delich • George Griffin • Jory Evertson • Jan Kurtis • Mark Emberton • Larry James  
 7TH ROW—Frank Chavez • Allen Cecchi • Joe Buerger • Michael Berkowitz • Duke Barrett • Don Ashley  
 BOTTOM ROW—Ken Allen • Eddie Aparacio



PURE WHITE



JET BLACK



SILVER SILK



MARINE PEARL



CHROME



BLACK DIAMOND PEARL



GOLD GLOSS



RED GLOSS



BLUE GLOSS



TEAK WOOD



ROSEWOOD



WALNUT

**Pearl**  
DRUMS

7373 North Cicero Avenue Lincolnwood, Illinois 60646

Norlin