

PEARL  
DRUMS  
PROFESSIONAL  
SERIES  
SUPPLEMENT

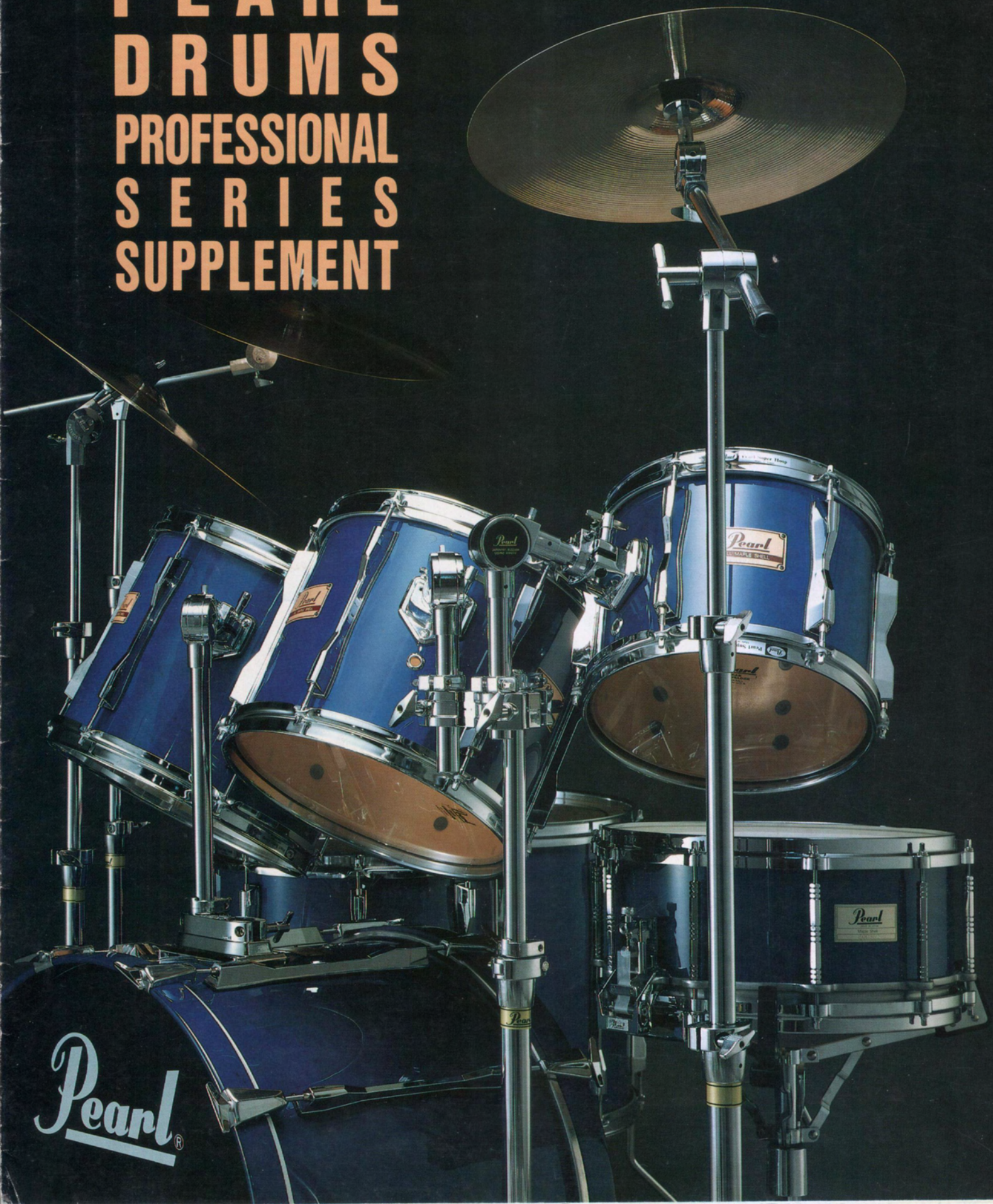

Pearl®

# PRESTIGE CUSTOM 8500 MLX SERIES



MLX-22D CUSTOM COMPONENT SET Illustrated in No.113 Sheer Blue Cymbals not included

Pearl's professional series drums have long been the pro's choice for beauty, cutting edge design and dependability. Offering the projection and warm sound of 100% maple on our MLX and MX series, and the uniquely powerful sound of 100% birch on our BLX series, both choices preferred by today's top pros are available with all the quality and craftsmanship that is Pearl. Two new highly polished transparent finishes, sheer blue (MLX and BLX) and liquid amber (MLX only), combined with newly designed hardware and exciting new features make Pearl's new professional series drums the serious choice for the serious player.

# HI-HAT STANDS

The all new H-950 hi-hat stand was designed with the working professional in mind. Features like a dual spring design with a wide spectrum easy grip tension adjustment system, footboard angle adjustability and rubber/spike convertible tipped feet all help to make a sturdier, more dependable hi-hat stand that is also easier to play than ever before.

The H-850W and H-850 feature our direct pull spring system with easy turn adjustment knob for fast, smooth and precise hi-hat action. Features also include sturdy double braced legs on the H-850W and standard single braced legs on the H-850, both have the new CL-95 clutch, nylon bushing joint and memory stop lock and are designed for years of trouble free use.

The H-750 is also a direct pull type hi-hat system that is light weight and offers the player a very fast and dependable hi-hat stand.



## FOOTBOARD ADJUSTMENT MECHANISM (H-950)

The footboard angle on the H-950 is easily adjusted from 11 degrees to 18 degrees to suit the player.



## HI-HAT CLUTCH

The CL-95 is Pearl's newly designed hi-hat clutch mechanism. Fully adjustable split design allows the CL-95 to work with most any hi-hat rod and comes standard on Pearl's H-950, H-850W, H-850 hi-hat stands and the RH-800 remote hat.

## SIDE HAT



The CLH-95A side hat offers you the convenience of playing a hi-hat anywhere from full open to fully closed position and leaving your feet free from pedals.

## REMOTE HAT



The RH-800 allows the player to mount the hi-hat at any location or angle and mount the foot pedal where it's most comfortable.

## HI-HAT ATTACHMENT



The HA-95 is a clamp system used with an AX-25 to attach any hi-hat stand to the bass drum.

## CONVERTIBLE TIP (H-950)

The H-950 features a quick spring action convertible spike/rubber tip.

# DRUM RACKS

Pearl's DR-1 and DR-2 drum racks feature an innovative square design for non-slip accessory attachment. The legs remove for easy folding storage with all clamps still in place making the next set-up a snap. The DR-1 is for single bass drum and the DR-2 is



a double bass drum rack, both are equipped with four PC-3 clamps.

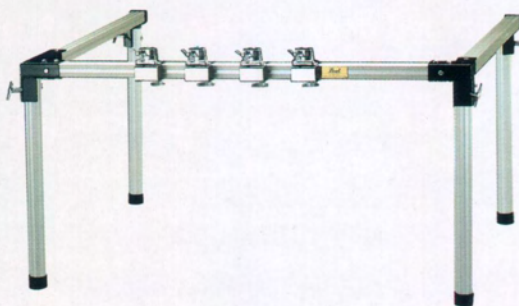

DR-1 : 700mm/ 27"(H)X1360mm/53"(W)X1200mm/46½"(D)

DR-2: 700mm/ 27"(H)X1660mm/65"(W)X1200mm/46½"(D)

## PIPE CLAMPS

Pearl's PC-3 accepts common ½" pipes used on tom and cymbal arms. The PC-2 adjusts for smaller pipes like mike holders.

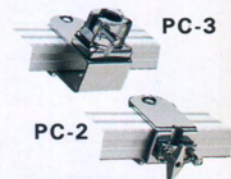

PC-3

PC-2

# CY CY

Pearl's and h... turing a... very he... full tele... cymbal... weight... structio... option.

Pearl's cymbal... This he... legs an... applica... as the h... The B-... weight

B-950W

# TOM

The pat... and TH-... er arms... feature a... mechani... curely li... any des... one turn... The TH-... bass dru... reach ap...

# CYMBAL BOOM STANDS CYMBAL STANDS

Pearl's new 950 series stands are the sturdiest and heaviest duty stands we've ever made. Featuring a wider stance, larger diameter tubes and very heavy construction. The B-950WT features full telescoping ability with memory lock, a new cymbal tilt ratchet system and new oversize counter weight. The B-950 features the same heavy construction and features but without the telescoping option.

Pearl's B-850W boom stand features the uni-lock cymbal tilter system with an unweighted boom arm. This heavy duty stand has sturdy double braced legs and is very well balanced and perfect for most applications. The B-850 has the same great features as the B-850W but with single braced legs.

The B-750 is great for applications where a light-weight and compact yet sturdy boom is required.

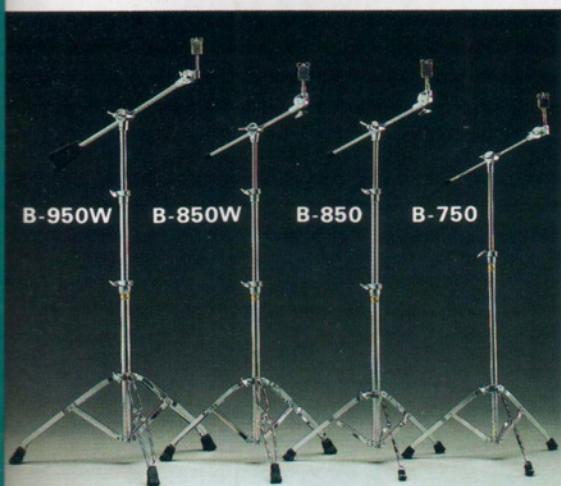

B-950W B-850W B-850 B-750

## NEW RATCHET CYMBAL TILTER (950 SERIES)

The new heavy duty ratchet tilter provides extra strength and durability and is offset for compact storage.



## NYLON BUSHING JOINT

Pearl's redesigned die-cast collar with nylon bushing insert is standard on all stands (except thrones) providing maximum holding power without the fear of overtightening.

## B-950WT

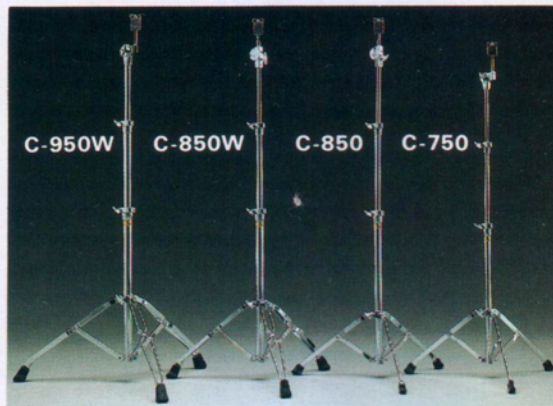
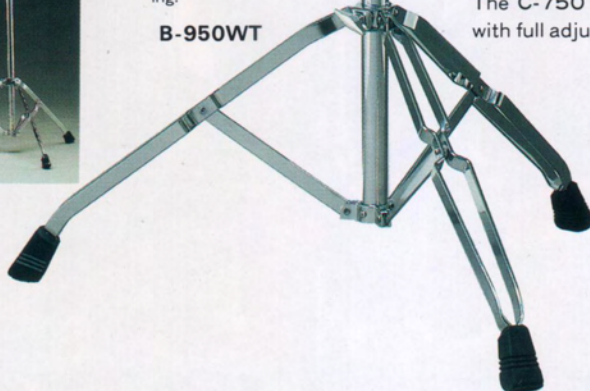

C-950W C-850W C-850 C-750

Pearl's C-950W cymbal stand has all the features of the B-950W without the boom attachment. Featuring large diameter tubes and new cymbal tilter, this is the heaviest cymbal stand designed for the heaviest hitters.

The C-850W and C-850 are also identical to their boom stand counterparts in design offering both a double braced leg (C-850W) and a single braced leg (C-850) model.

The C-750 is a professional quality cymbal stand with full adjustability and very compact.

## TOM HOLDERS

The patented TH-95 and TH-95S tom holder arms from Pearl feature a unique brake mechanism that securely locks a tom at any desired angle with one turn of a drum key. The TH-95 arm is for bass drum and longer reach applications.

Pearl's TH-85 and TH-85S tom arms have a deep gear locking system that allows the tom to be set at the desired angle and tightened using a thru bolt and wing nut. Memory locks are provided for quick set-up.

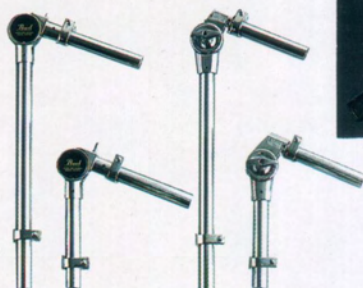

TH-95 TH-95S TH-85 TH-85S



TH-85B

The TH-85B tom tom boom holder features a long boom arm with a newly designed oversized counter weight.

## MICROPHONE HOLDERS

Pearl's mike arms are the best way to mike your kit without a maze of stands. They are simply attached by one of Pearl's adaptors and available with long or short arm.

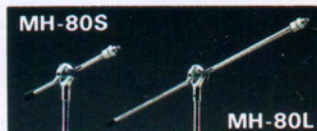

MH-80S

MH-80L

# SNARE DRUM STANDS TOM TOM STANDS

The S-950W is the ultimate snare stand equipped with the universal angle adjustment system, quick set and release snare basket, new rubber drum clamp arms and a newly designed base featuring a wider stance and double braced legs.

The S-850W and S-850 snare stands are very similar in design featuring a uni-lock type angle adjustment system and large rubber feet for stability. The S-850W has double braced legs while the S-850 features single braced legs.

Pearl's S-750 snare stand is very compact while offering great adjustability with a low center of gravity design.



S-950W

## QUICK SET AND RELEASE MECHANISM (S-950W)

The quick set and release mechanism of the S-950W features a large basket knob for easy adjustment with set screw memory. The basket release allows the drum to be removed without changing the grip adjustment for quick set-up or changing drums.



S-850W

S-850

S-750

The T-850WB is the ultimate stand for mounting a single tom, featuring double braced legs, full height and boom adjustability and newly designed oversize counter weight. Pearl's T-980W and T-850 twin tom stands are designed for mounting two toms with independent adjustability. The T-980W features double braced legs with two TH-95S tom arms. The T-850 stand has single braced legs and TH-85S arms.



T-850WB

T-980W

T-850

## CYMBAL HOLDERS

Pearl's cymbal holders are the top sections of our popular cymbal boom stands offering a player the ability to mount a cymbal from a rack or an adaptor clamp where a full stand could not be used.

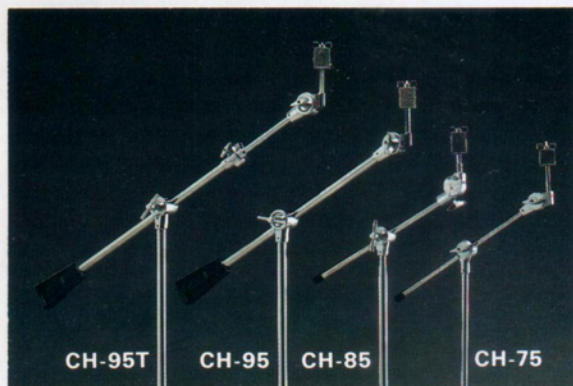

CH-95T

CH-95

CH-85

CH-75

## ADAPTORS

Pearl's die-cast adaptors are designed for mounting various accessories, tom holders and cymbal holders to any stand or pipe of proper size. The AX-20 accepts one tom or cymbal holder, the AX-30 accepts two and the AX-25 (or longer AX-25L) swivels a full 360° at both ends.

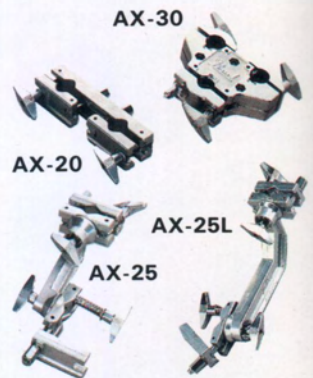

AX-30

AX-20

AX-25L

AX-25

# DRUM PEDALS



P-880

Pearl's P-880 chain drive pedal is considered by many as the best drum pedal available. Featuring our exclusive felt lined channel instead of a sprocket to eliminate chain noise and retain the precision of chain drive.

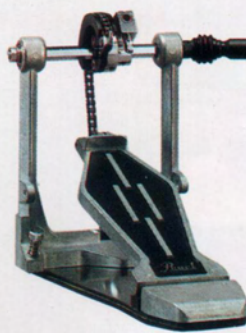

P-880TW (shown with P-880)

The P-880TW is Pearl's exclusive chain drive wheel action twin bass pedal. With its hexagonal connecting shaft and two universal joints, a wide variety of placement options are available. The P-880TW is the slave unit only. The P-882TW is complete as shown with two pedals, or the P-882TWL is a complete two pedal set-up for the lefty.

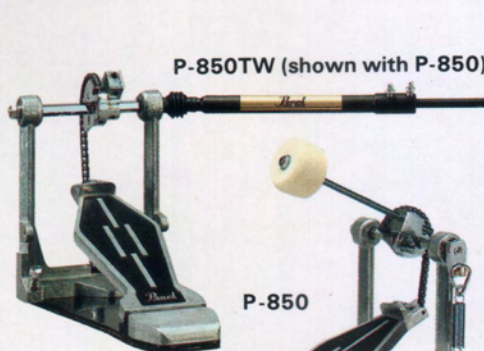
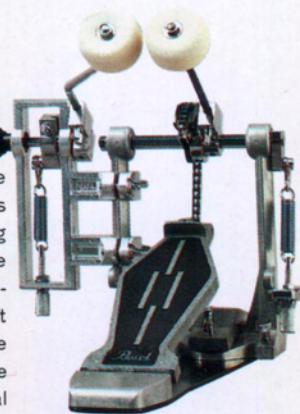

P-850TW (shown with P-850)

P-850

Pearl's P-850TW is the slave double pedal unit with chain and sprocket design and similar to the P-880TW in all other aspects. As with the P-880TW, they both can mount to other pedals with a unique clamp system. The complete two pedal set-up is also available as model P-852TW.

The P-850 chain drive pedal features a chain and sprocket drive that is very popular with today's players. Similar in design to the P-880, the P-850 also offers beater angle adjustment without affecting spring tension.

**NOTE: P-850TW, P-852TW and P-850 are not available in USA.**



P-800

P-750

The P-800 bass drum pedal features the wheel drive action system with strap design, beater angle adjustment without affecting spring tension and quick quiet action.

The P-750 is similar to the P-800 in design also offering the wheel drive action system and strap design.

## TWIN PEDAL ATTACHMENT



The TA-90 is used to stabilize the twin pedal (P-880TW or P-850TW) to a hi-hat stand and comes complete with a AX-25 adaptor.

## DRUMMERS THRONES

Pearl's drummers thrones offer the ultimate in comfort and stability. The D-900 features a thick padded cloth seat, threaded height adjustability from 485mm/19" thru 700mm/27½" and double braced legs. The D-850 throne also features a padded cloth seat and double braced legs and is adjustable from 450mm/17¾" thru 630mm/24¾". Pearl's D-730 throne features a low center of gravity design with single braced legs and padded vinyl seat.



D-900

D-850

D-730

## TUNING KEYS

Pearl's K-025 newly designed tuning key fits lugs and adjustment screws on all Pearl Drums. The K-029 speed key allows you to change heads quickly with more available torque for tightening.

K-025



K-029





MLX-22D-5 Illustrated in No.114 Liquid Amber Cymbals not included

Pearl's MLX kit features 6 ply all maple shells, beautiful hi-tension lugs, gleaming piano lacquer finishes and our 6 1/2" x 14" brass shell free floating system snare drum. The MX outfit has the same great maple shell with various covering material options. Pearl's BLX kit features all birch shells with beautiful lacquer finishes and the 6 1/2" x 14" steel shell free floating system snare drum.

## FLOOR TOM LEG BRACKET

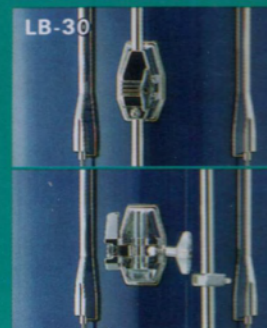

Pearl's new professional leg bracket features hinged access with memory lock for quick set-up and tear-down.

## BASS DRUM SPUR

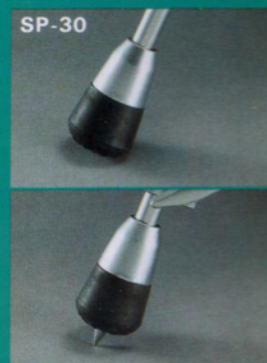

Our newly designed spur features fast spring action to quickly convert from rubber to spike tip.

## PEARL PROFESSIONAL DRUM SERIES OUTFIT COMPOSITIONS

|                   |              |          | PRESTIGE CUSTOM 8500 MLX SERIES |           |            |            |           |           |            |            |
|-------------------|--------------|----------|---------------------------------|-----------|------------|------------|-----------|-----------|------------|------------|
|                   |              |          | MLX-22D-5                       | MLX-22D-7 | MLX-22DW-7 | MLX-22DW-9 | MLX-24D-5 | MLX-24D-7 | MLX-24DW-7 | MLX-24DW-9 |
| BASS DRUM         | 16" x 22"    | MLX-222D | •                               | •         | ••         | ••         |           |           |            |            |
|                   | 16" x 24"    | MLX-210D |                                 |           |            |            | •         | •         | ••         | ••         |
| TOM TOM           | 8" x 10"     | MLX-210D |                                 | •         |            |            |           |           |            |            |
|                   | 10" x 12"    | MLX-212D | •                               | •         | •          | •          |           |           |            | •          |
|                   | 11" x 13"    | MLX-213D | •                               | •         | •          | •          |           |           |            | •          |
|                   | 12" x 14"    | MLX-214D |                                 | •         |            | •          | •         |           | •          | •          |
| FLOOR TOM         | 14" x 15"    | MLX-215D |                                 |           |            |            |           | •         |            | •          |
|                   | 16" x 16"    | MLX-2116 | •                               | •         | •          | •          |           |           | •          | •          |
| SNARE DRUM        | 16" x 18"    | MLX-2118 |                                 |           |            |            |           |           | •          | •          |
|                   | 6 1/2" x 14" | *B-914D  | •                               | •         | •          | •          | •         | •         | •          | •          |
| HI-HAT STAND      | H-950        | •        | •                               | •         | •          | •          | •         | •         | •          | •          |
| SNARE DRUM STAND  | S-950W       | •        | •                               | •         | •          | •          | •         | •         | •          | •          |
| CYMBAL STAND      | C-850W       | •        | •                               | •         | •          | •          | •         | •         | •          | •          |
| CYMBAL BOOM STAND | B-850W       | •        | ••                              | •••       | •••        | •          | ••        | •••       | •••        | •••        |
| TWIN TOM STAND    | T-980W       |          |                                 | •         | •          |            |           |           |            |            |
| DRUM PEDAL        | P-880        | •        | •                               | •         | ••         | •          | •         | ••        | ••         | ••         |
| TOM HOLDER        | TH-95        | ••       | ••••                            | •         | ••••       | ••         | ••        | ••••      | ••••       | ••••       |
| ADAPTOR           | AX-20        |          | ••                              |           |            |            |           | ••        |            |            |

Cymbals not included

The chart above is for outfit composition of the MLX Series (maple shell, lacquered). This chart also applies to MX Series (maple shell, covered) and BLX Series (birch shell, lacquered) by changing the prefix MLX to either MX or BLX. Please note that \*B-914D free floating system brass shell snare drum is available with MLX and MX outfits only. BLX outfits receive S-814D free floating system steel shell snare drum.

# SNARE DRUMS

The exciting new additions to our snare drum line includes an aluminum shell snare drum in two sizes of our unique free floating system, and two sizes available with newly designed hi-tension lugs and snare strainer. The perfectly rolled 2 mm aluminum shell adds great tonal character that must be heard to be fully described. Also our new maple shell 3½" piccolo free floating system snare drum features the same sharp attack and quick response made popular by our brass shell piccolo, but with a warmer crisp sound that is naturally maple.

Pearl's aluminum shell free floating system snare drum could be the optimum snare drum material. Offering a tight sharp sound when tuned high and a fat, heavy yet tight sound when tuned low and without annoying overtones. Available in 6½" and 5" depths the free floating system gives you the ability to change shells to suit various performing situations.

AL-814D



AL-6214D



Pearl's highly polished silver lacquered aluminum shell snare drum is also available with hi-tension lugs and more traditional styling. The unique sound of aluminum creates a sound completely different from other metal snare drums.

B-914P



B-914ED



Pearl's very popular brass shell snare drums feature our free floating system and the great sound of brass that is so commonly used in musical instruments for its blend of tonal color and projection.

With the growing popularity of the piccolo snare sound with today's top pros, it is common to see them used as both the secondary and the main snare drum. This 3½" beautifully lacquer finished maple shell drum features our free floating system with die-cast hoops.

G-914P



| Model    | Size      | Shell Material | Lugs      | Hoops          | Strainer | Finish           |
|----------|-----------|----------------|-----------|----------------|----------|------------------|
| AL-814D  | 6½" x 14" | Aluminum       | 10 double | Super Hoops    | S-011E   | Silver-Lacquered |
| AL-814   | 5" x 14"  | Aluminum       | 10 double | Super Hoops    | S-011E   | Silver-Lacquered |
| AL-6214D | 6½" x 14" | Aluminum       | 10 double | Super Hoops    | S-013    | Silver-Lacquered |
| AL-6214  | 5½" x 14" | Aluminum       | 10 double | Super Hoops    | S-013    | Silver-Lacquered |
| G-914P   | 3½" x 14" | Maple          | 10 double | Die-cast Hoops | S-011E   | Lacquered        |
| B-914ED  | 8" x 14"  | Brass          | 10 double | Die-cast Hoops | S-011    | Brass-Lacquered  |
| B-914P   | 3½" x 14" | Brass          | 10 double | Die-cast Hoops | S-011E   | Brass-Lacquered  |

## AVAILABLE COLORS

|                                    | No. 102<br>NATURAL<br>MAPLE | No. 103<br>PIANO<br>BLACK | No. 107<br>CORAL<br>RED | No. 108<br>CHARCOAL<br>GREY | No. 109<br>ARCTIC<br>WHITE | No. 110<br>SEQUOIA<br>RED | No. 113<br>SHEER<br>BLUE | No. 114<br>LIQUID<br>AMBER |
|------------------------------------|-----------------------------|---------------------------|-------------------------|-----------------------------|----------------------------|---------------------------|--------------------------|----------------------------|
|                                    |                             |                           |                         |                             |                            |                           |                          |                            |
| PRESTIGE CUSTOM 8500<br>MLX SERIES | •                           | •                         | •                       | •                           | •                          | •                         | •                        | •                          |
| PRESTIGE STUDIO 7500<br>BLX SERIES |                             | •                         | •                       |                             | •                          | •                         | •                        |                            |

Available color finishes for the "CUSTOM 8500 MX SERIES" includes; No.21 Smoky Chrome, No.31 Jet Black, No.33 Pure White, No.38 Stainless Steel and No.71 Ferrari Red.

Specifications are subject to change without notice.  
June 1988 A630610 Printed in Japan

*Pearl*®