

PEARL DRUM PEDAL

P-2000C / P-2000B

Instruction Manual

Congratulations on your purchase!
 To get optimum performance of your PowerShifter Eliminator Pedal,
 please read this Instruction Manual before playing.

PowerShifter
ELIMINATOR

ADVANCED
 HARDWARE SYSTEMS

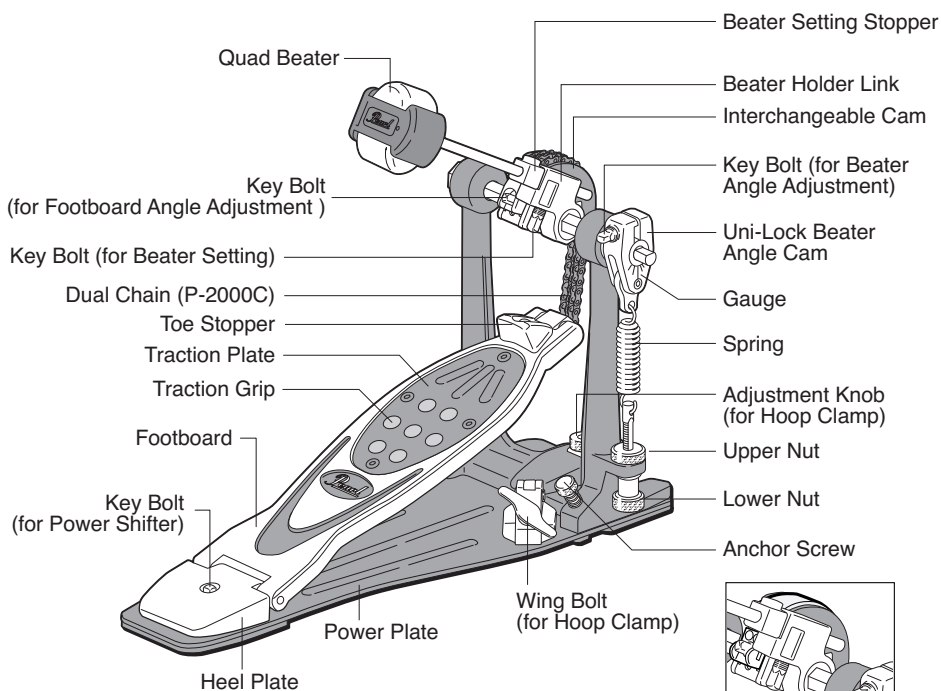

P-2000C

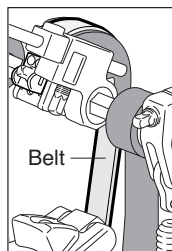

P-2000B

Quad Beater

The Quad Beater has four striking surfaces, each capable of producing a different sound. Please refer to the following chart to determine the sound best suited to your playing style (Fig. 1).

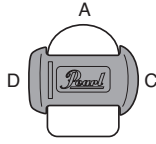

B Fig. 1

Surface	Surface Material	Contact Area	Sound
A	Felt	Spot	Warm Sound with Sharp Attack
B	Felt	Line	Warm Sound with Fat Attack
C	Plastic	Spot	Hard Sound with Sharp Attack
D	Plastic	Line	Hard Sound with Fat Attack

Beater Setting

Insert the Quad Beater into the Beater Holder Link with the desired face toward the bass drum head until it stops against the Beater Setting Stopper, and tighten the Key Bolt with a Tuning Key (Fig.2-A). Make sure that the Beater Setting Stopper is flush against the Beater Holder Link (Fig.2-B). To adjust the height of the Quad Beater, loosen the Allen screw on the Beater Holder Link with the provided hexagonal wrench. Set the Quad Beater to the desired height and re-tighten the Allen screw (Fig.2-C).

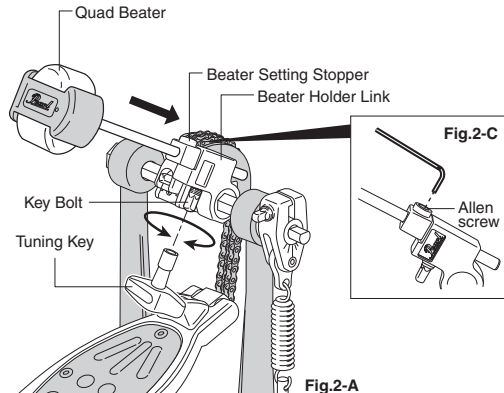

Fig.2-A

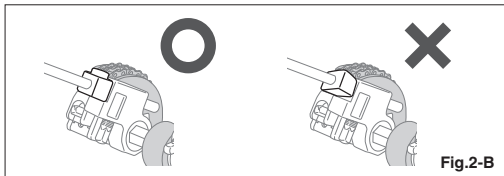

Fig.2-B

Tip

The Beater Setting Stopper preserves the height setting if the beater is removed when transporting the pedal.

Beater Angle Adjustment

The beater angle can be adjusted by loosening the Key Bolt on the Uni-Lock Beater Angle Cam and swinging the beater to the desired angle. Simply re-tighten the Key Bolt to secure the angle. The desired angle can be easily marked with the Gauge on the Cam (Fig.3).

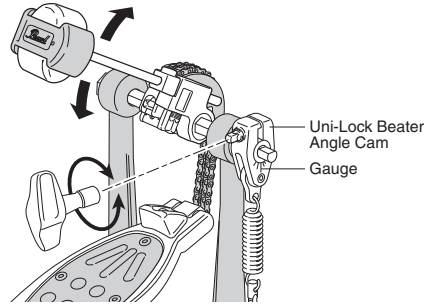

Fig.3

Footboard Angle Adjustment

The footboard angle is adjustable by loosening the Key Bolt as shown (Fig.4) and sliding the Drive Connector of the chain or belt to one of three positions and re-tighten the Key Bolt.

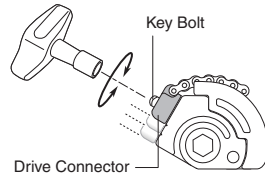

Fig.4

Note

Remove the Beater for easier adjustment.

Spring Tension Adjustment

To adjust spring tension, loosen the Upper Nut then adjust the Lower Nut to the desired spring tension. Counterturn the Upper Nut and Lower Nut to secure the spring tension (Fig.5).

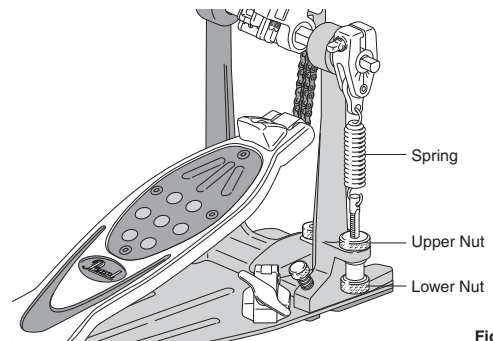

Fig.5

Toe Stopper

The Toe Stopper prevents your foot from sliding into the chain or belt while playing. If not needed, it can be removed easily by unscrewing the Key Bolt (Fig.6).

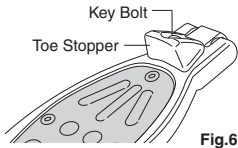

Fig.6

Anchor Screw

The Anchor Screws can be extended as needed to help prevent the bass drum from creeping forward while playing (Fig.7).

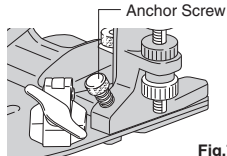

Fig.7

CAUTION

Use only on carpeted surface to prevent damage to the floor.

Interchangeable Cam System

Our exclusive Cam System provides four interchangeable color-coded cams (black, white, blue and red) allowing you to quickly change the power and feel of the pedal to suit your individual playing style. From the factory, the Black Cam is mounted to the P-2000C Chain Drive Pedal; the Red Cam is mounted to P-2000B Belt Drive Pedal. When you change from the original Cam to another, push the Release Button on the Wheel and remove the Cam as shown (Fig.9).

While pushing the Release Button, snap another Cam in place and make sure that the Cam is seated correctly (Fig.10).

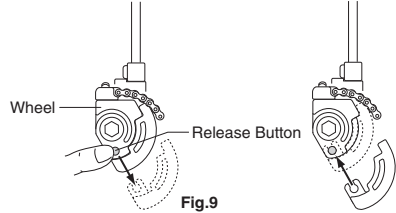

Fig.9

Fig.10

Note

Using a pedal without mounting a Cam on the Wheel will damage the pedal. ONLY use the pedal with a Cam attached.

Hoop Clamp system

Insert the bass drum hoop into the Clamp and turn the Wing Bolt to secure. The Eliminator's Hoop Clamp system comes preset from the factory to accommodate most bass drum hoops but if necessary it can be adjusted to fit thicker and narrower hoops. Loosen the Allen screw on the Adjustment Knob with the provided Allen wrench as shown (Fig. 8) and tighten or loosen the Adjustment Knob until proper fit is achieved then re-tighten the Allen screw.

If the heel of the pedal lifts while playing, try loosening the Adjustment Knob to change the angle of the Hoop Clamp until the pedal remains flat.

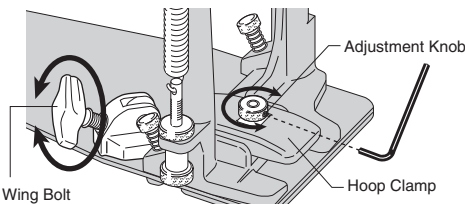

Fig.8

Included 4				Optional 2	
Black	White	Blue	Red	Purple	Yellow

Linear Action Cam / Black :

This is Pearl's original "perfect circle" Cam design. It offers superior power and a very natural, perfectly balanced action and smooth feel.

Oversized Linear Cam / White :

The White Cam is a slightly over sized "perfect circle" Cam. It offers a very natural, smooth action, with great power and balance, with a slightly lighter pedal feel.

Progressive Cam / Blue :

This is the very popular "off-center" axis type Cam design. It offers a light feel in the beginning that accelerates with speed and power upon impact.

Radical Progressive Cam / Red :

The Red Cam features an extreme "off-center" axis design. The action is similar to the Blue Cam but with a lighter feel at the beginning of the stroke.

Aggressive Action Cam / Purple :

The Purple Cam provides aggressive acceleration for huge power and response, second only to the Red Cam. (CAM-PL)

Inverse Action Cam / Yellow :

The Yellow Cam provides a slight inverse action. When maximum power is required, this is the Cam of choice. (CAM-YL)

Traction Grip and Traction Plate Adjustment

The Traction Grip Dots can be totally removed or inserted as needed to custom tailor the amount of traction for your personal playing style. To remove the Traction Grip Dots, loosen the Allen screws holding the Traction Plate with the provided hexagonal wrench and remove the Traction Plate from the footboard (Fig.11). The Traction Plate is also reversible to provide just the right amount of grip at either the front or rear of the footboard (Fig.12).

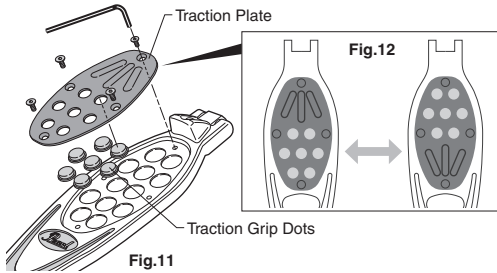

Note

When putting the Traction Plate back, finger-tighten the four screws to prevent cross-threading; then tighten the screws securely. Do not use the Pedal without the Traction Plate mounted. It could cause injury to your foot.

Rubber Mats

To maximize traction of the rubber mats underneath the Power Plate keep them clean and dust free using a damp cotton towel.

CAUTION

- ◆ Periodically check all Allen Screws for tightness and tighten them with the provided Allen Wrenches as needed.
- ◆ Periodically apply lube to all moving parts such as the Chain, Cam Roller, Footboard Hinge, etc. for optimal speed and extended life of your pedal. Bearings should be lubricated with grease, not liquid oil.

PowerShifter

The PowerShifter function allows you to change the feel and action of the pedal by shifting the footboard position back and forth. To change the position, loosen the Key Bolt in the heel of the footboard and move the footboard to the desired position: A, B or C. Tighten the Key Bolt again (Fig.13).

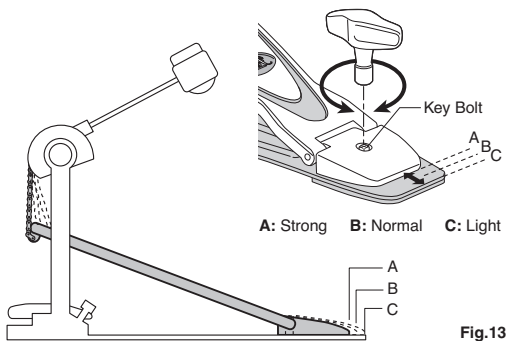

Note

Make sure that the heel is flush with the Power Plate to prevent damage to the pedal.

Pearl

<http://www.pearldrums.com>

Products and specifications are subject to change without notice.

Printed in China

-1406-